

# Mode, Status & current during Power Up

This Application Note is applied to below products.

- K1B5616B2M, K1B5616BAM, K1B5616BBM
- K1B2816B2A, K1B2816BAA, K1B2816BBA

Aug. 2006

Product Planning & Application Engineering Team

MEMORY DIVISION  
SAMSUNG ELECTRONICS Co., LTD

# Status and Current (When S/W MRS is being used & /PS pin is fixed High)

## Case1

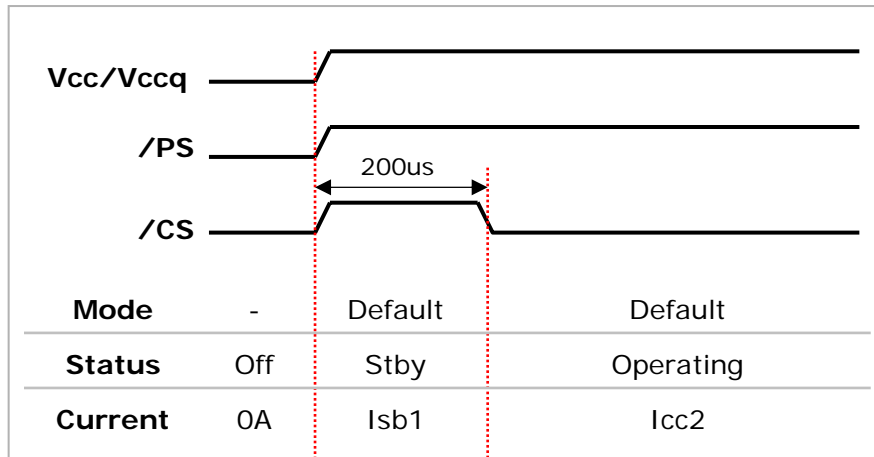

## Case2

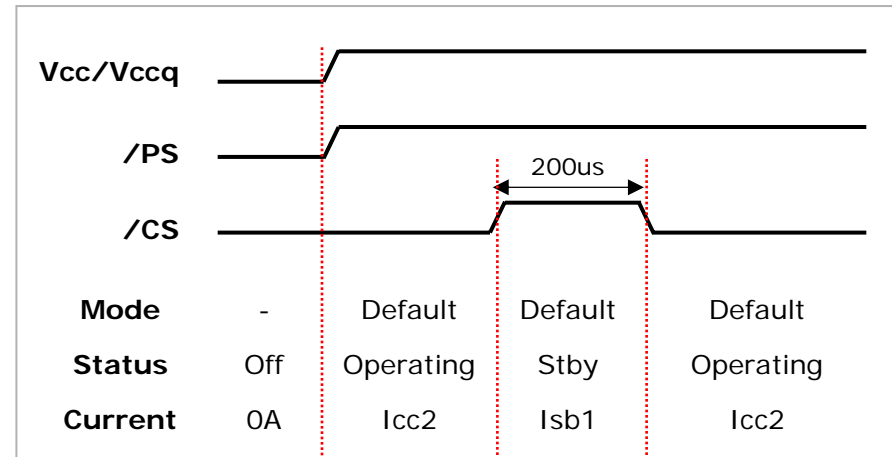

## Case3

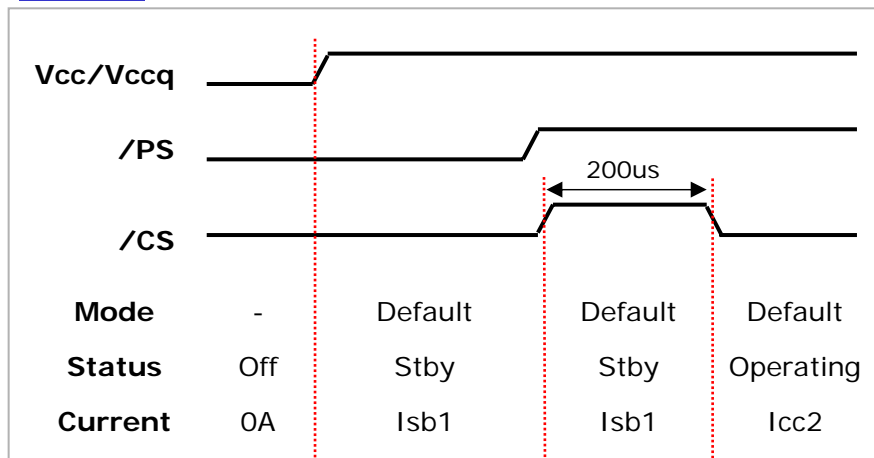

## Case4

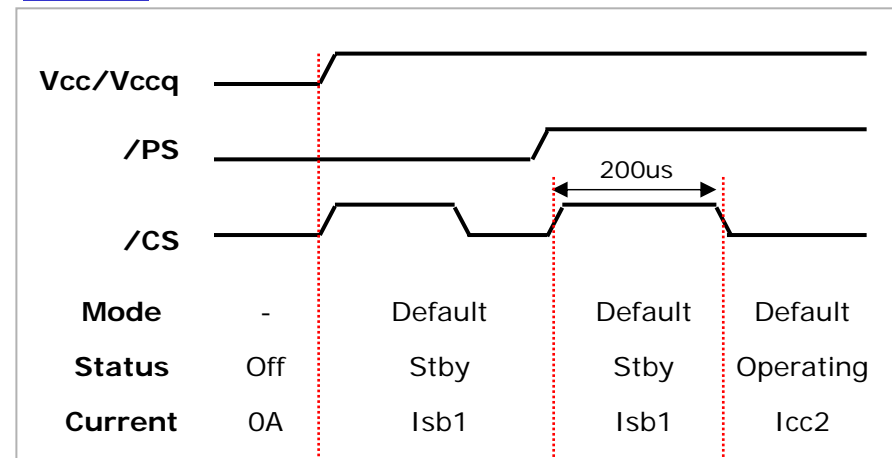

Note)

**Mode1:** Asynch Read / Asynch Write. **Mode2:** Synch Read / Asynch Write. **Mode3:** Synch Read / Synch Write

**Default:** Mode1, DPD disable, PAR disable

**Stby:** Standby **DPD:** Deep Power Down. **PAR:** Partial Refresh

**Isb1:** Standby Current

\* Default Mode is Guaranteed

# Status and Current (When Pin MRS is being used)

## Case1

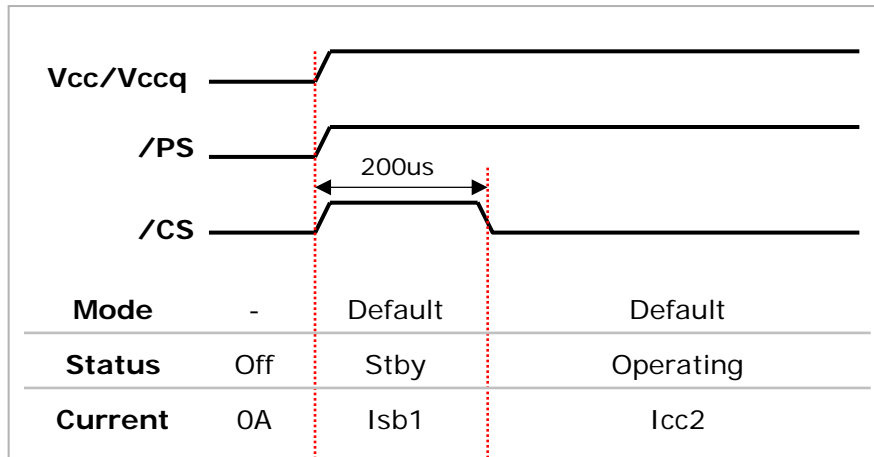

## Case2

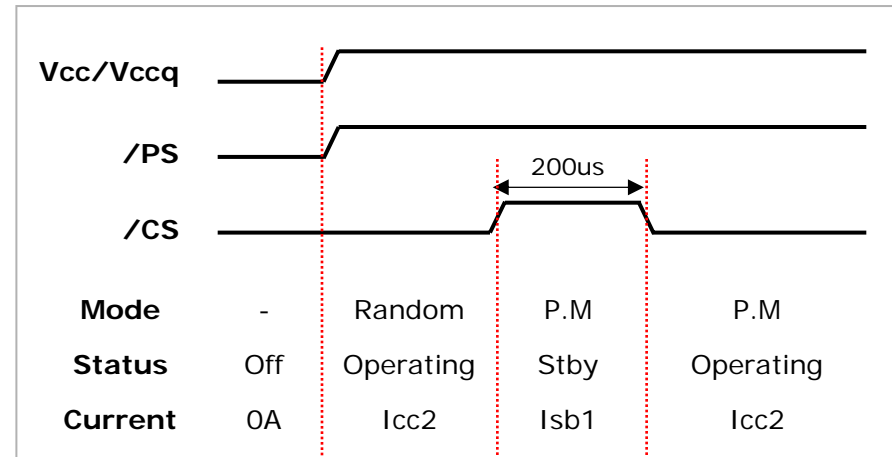

## Case3

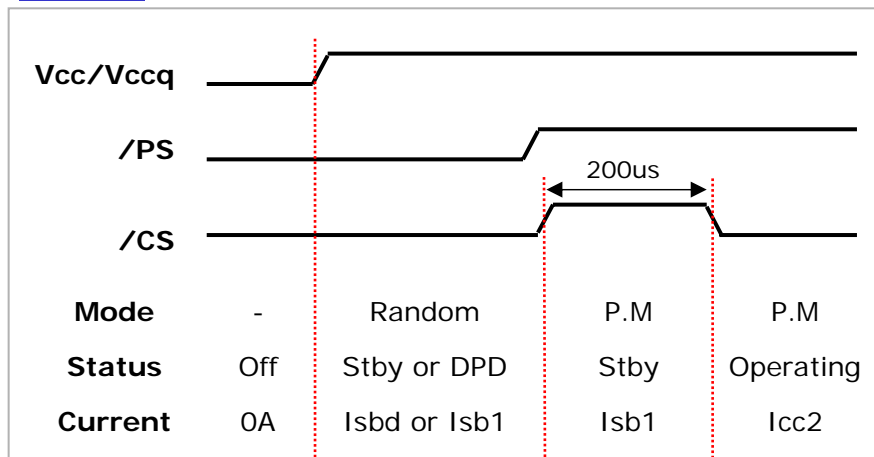

## Case4

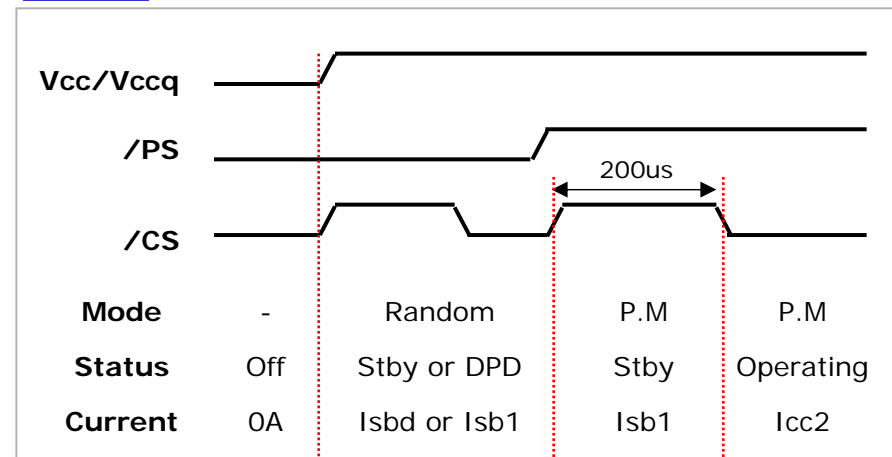

Note)

**Mode1:** Asynch Read / Asynch Write. **Mode2:** Synch Read / Asynch Write. **Mode3:** Synch Read / Synch Write

**Default:** Mode1. DPD disable, PAR disable. **Random:** One of Mode1, Mode2 or Mode3. **P.M:** Previous Mode

**Stby:** Standby **DPD:** Deep Power Down **PAR:** Partial Refresh

**Isb1:** Standby Current. **Isbd:** Deep Power Down Current

**\* Default Mode can NOT be Guaranteed and it is requested to implement MRS before UtRAM Access**

# Functional Table during Power up

Signal			Mode	Status	Current	Comment
Vcc	/PS	/CS				

## - When S/W MRS is being used & /PS pin is fixed High

> min. Vcc	Low	Low	Default	Stby	< Isb1	* Default Mode is <b>Guaranteed</b>
> min. Vcc	Low	High	Default	Stby	< Isb1	
> min. Vcc	High	Low	Default	Operating	< ICC2	
> min. Vcc	High	High	Default	Stby	< Isb1	

## - When /PS pin MRS is being used

> min. Vcc	Low	Low	Random	DPD or Stby	< Isbd or < Isb1	* <b>Default Mode can NOT be Guaranteed</b> and it is requested to implement MRS before UtRAM Access * Implementing MRS is possible at any time.
> min. Vcc	Low	High	Random	DPD or Stby	< Isbd or < Isb1	
> min. Vcc	High	Low	Random	Operating	< ICC2	
> min. Vcc	High	High	Default	Stby	< Isb1	

Note)

**min.Vcc:** 1.7V for 1.8V Product, 2.7V for 3.0V Product.

**Mode1:** Asynch Read / Asynch Write. **Mode2:** Synch Read / Asynch Write. **Mode3:** Synch Read / Synch Write

**Default:** Mode1. DPD disable, PAR disable. **Random:** One of Mode1, Mode2 or Mode3

**Stby:** Standby **DPD:** Deep Power Down. **PAR:** Partial Refresh

**Isb1:** Standby Current. **Isbd:** Deep Power Down Current