Protection Sequence For NOR Flash Application Note

Version 1.0, May 2009

Preliminary

Samsung Electronics

Copyright © 2009 Samsung Electronics Co.,LTD.



Copyright © 2009 Samsung Electronics Co, Ltd. All Rights Reserved.

Though every care has been taken to ensure the accuracy of this document, Samsung Electronics Co, Ltd. cannot accept responsibility for any errors or omissions or for any loss occurred to any person, whether legal or natural, from acting, or refraining from action, as a result of the information contained herein. Information in this document is subject to change at any time without obligation to notify any person of such changes.

Samsung Electronics Co, Ltd. may have patents or patent pending applications, trademarks copyrights or other intellectual property rights covering subject matter in this document. The furnishing of this document does not give the recipient or reader any license to these patents, trademarks copyrights or other intellectual property rights.

No part of this document may be communicated, distributed, reproduced or transmitted in any form or by any means, electronic or mechanical or otherwise, for any purpose, without the prior written permission of Samsung Electronics Co, Ltd.

The document is subject to revision without further notice.

All brand names and product names mentioned in this document are trademarks or registered trademarks of their respective owners.

Contact Information

Mobile/Flash Application Engineering Group
Memory Division, Semiconductor Business
Samsung Electronics Co., Ltd
Address : San #16, Banwol-Dong, Hwasung-City,
Gyeonggi-Do, Korea, 445-701

Purpose

This application note will guide you to use Protection operation of NOR Flash in the right direction. It describes how to keep protection command sequence. This is helpful for mobile system software engineers.

Definitions and Acronyms

Definitions and Acronyms	Description
DYB	Dynamic Protection Bit
PPB	Persistent Protection Bit
PWA	Password Address
PWD	Password Data being verified
PL	Password Protection Mode Lock

References

- Samsung NOR Flash Data Sheet
- Samsung Mobile Planning Group Materials

Table Of Contents

1. Definition of Block Protection & Un-protection	5
2. NOR Flash Block Protection Commands	5
3. Idle Status after Protection Commands	6
4. Exit to Read Mode	7

Preliminary

1. Definition of Block Protection & Un-Protection

To protect the block from accidental writes, the block protection/un-protection command sequence is used. On power up, all blocks in the device are protected. To unprotect a block, the system **must write** the block un-protection command sequence. The first two cycles are written: addresses are don't care and data is 60h. Using the third cycle, the block address (ABP) and command (60h) is written, while specifying with addresses A6, A1 and A0 whether that block should be protected (A6 = VIL, A1 = VIH, A0 = VIL) or unprotected (A6 = VIH, A1 = VIH, A0 = VIL). After the third cycle, the system can continue to protect or unprotect additional cycles, or exit the sequence by writing F0h.

The device offers three types of data protection at the block level:

- The block protection/un-protection command sequence disables or re-enables both program and erase operations in any block.
- When /WP is at VIL, the two outermost blocks are protected.
- When VPP is at VIL, all blocks are protected.

Note that user never float the Vpp and WP, that is, Vpp is always connected with VIH, VIL or VID and WP is VIH or VIL.

2. NOR Flash Block Protection Commands

Enhanced Block Protection(EBP) is comprised of below table and next flow-chart. Refer to block protection commands table.

Command Sequence		Cycle	1st Cycle	2nd Cycle	3rd Cycle	4th Cycle	5th Cycle	6th Cycle	7th Cycle
Password Program(1,2)	Addr	4	555H	2AAH	555H	XX[0-3]H			
	Data		AAH	55H	38H	PD[0-3]			
Password Verify(2,4,5)	Addr	4	555H	2AAH	555H	PWA[0-3]			
	Data		AAH	55H	C8H	PWD[0-3]			
Password Unlock(3,6,7)	Addr	7	555H	2AAH	555H	PWA[0]	PWA[1]	PWA[2]	PWA[3]
	Data		AAH	55H	28H	PWD[0]	PWD[1]	PWD[2]	PWD[3]
PPB Program(1,2,8)	Addr	6	555H	2AAH	555H	(BA)WP	(BA)WP	(BA)WP	
	Data		AAH	55H	60H	68H	48H	RD(0)	
Master locking bit Set	Addr	3	555H	2AAH	555H				
	Data		AAH	55H	F1H				
PPB Status	Addr	4	555H	2AAH	555H	(BA)WP			
	Data		AAH	55H	90H	RD(0)			
All PPB Erase(1,2,9,10)	Addr	6	555H	2AAH	555H	WP	(BA)	(BA)WP	
	Data		AAH	55H	60H	60H	40H	RD(0)	

PPB Lock Bit Set	Addr	3	555H	2AAH	555H				
	Data		AAH	55H	78H				
PPB Lock Bit Status(11)	Addr	4	555H	2AAH	555H	BA			
	Data		AAH	55H	58H	RD(1)			
DYB Write(3)	Addr	4	555H	2AAH	555H	BA			
	Data		AAH	55H	48H	X1H			
DYB Erase(3)	Addr	4	555H	2AAH	555H	BA			
	Data		AAH	55H	48H	X0H			
DYB Status(2)	Addr	4	555H	2AAH	(DA)555H	BA			
	Data		AAH	55H	58H	RD(0)			
PPMLB Program(1,2,8)	Addr	6	555H	2AAH	555H	PL	PL	PL	
	Data		AAH	55H	60H	68H	48H	RD(0)	
PPMLB Status(1)	Addr	5	555H	2AAH	555H	PL	PL		
	Data		AAH	55H	60H	48H	RD(0)		
SPMLB Program(1,2,8)	Addr	6	555H	2AAH	555H	BL	BL	BL	
	Data		AAH	55H	60H	68	48	RD(0)	
SPMLB Status(1)	Addr	5	555H	2AAH	555H	BL	BL		
	Data		AAH	55H	60H	48	RD(0)		
OTP Protection bit Program(1,2)	Addr	6	555H	2AAH	555H	OW	OW	OW	
	Data		AAH	55H	60H	68H	48H	RD(0)	
OTP Protection bit Status	Addr	5	555H	2AAH	555H	OW	OW		
	Data		AAH	55H	60H	48H	RD(0)		

Figure 1 NOR Block Protection Commands Table

3. Idle Status after Protection Commands

During this case device dose not return to read mode. All commands except Exit OTP Command are ignored and remain the pre-status.

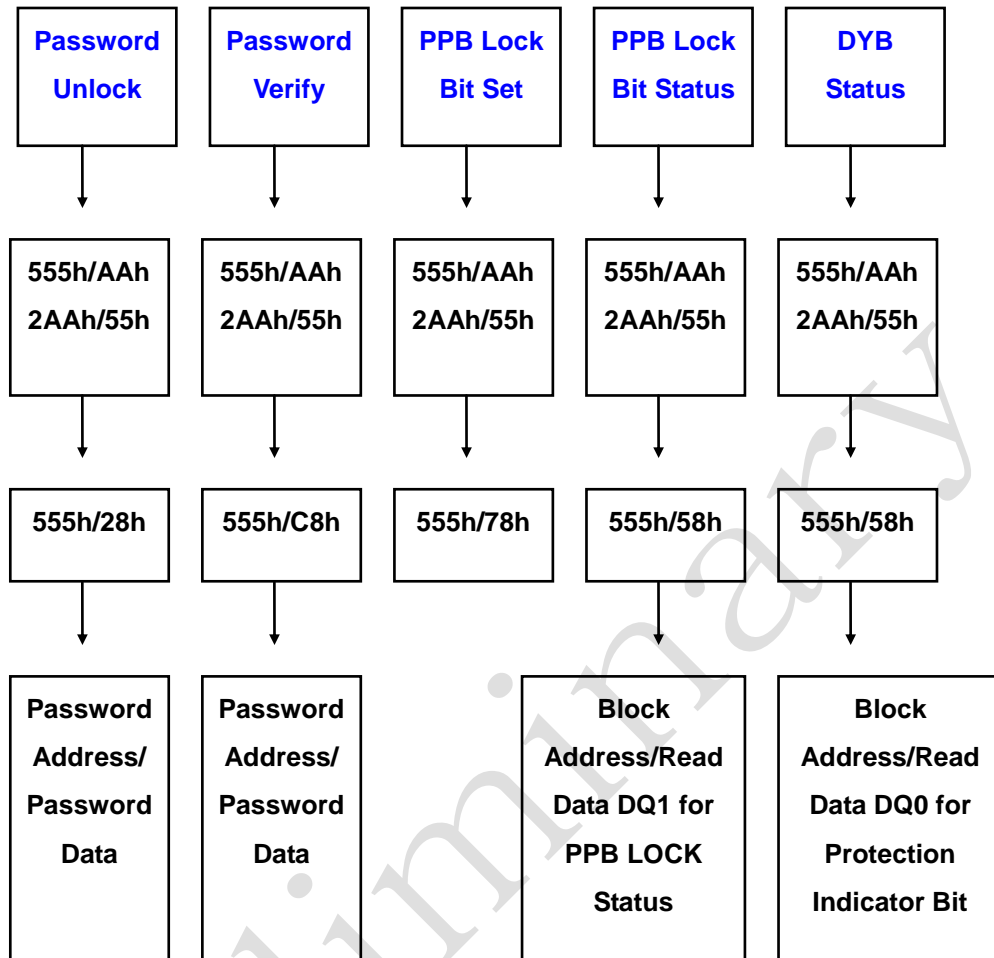
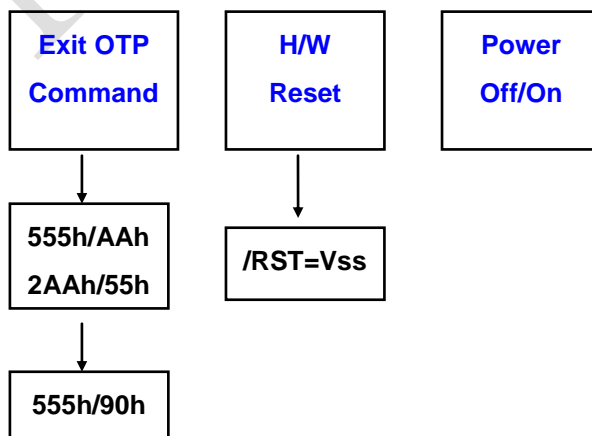

Figure 2 Idle Status after Protection Commands Flow Chart

4. Exit to Read Mode

Exit to read mode, there are three methods. First using OTP Command, Second H/W Reset this means that /RST is tied to Vss. The last method is application power off and then Power on. Below flow chat show that three methods sequence.



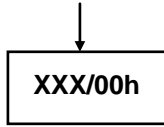

Figure 3 Exit to Read Mode Flow Chart

Preliminary