**APPLICATION NOTES For
Ni-MH BATTERY CHARGER
S3F94xx-SERIES
MICROCONTROLLERS**

Revision 0



Important Notice

The information in this publication has been carefully checked and is believed to be entirely accurate at the time of publication. Samsung assumes no responsibility, however, for possible errors or omissions, or for any consequences resulting from the use of the information contained herein.

Samsung reserves the right to make changes in its products or product specifications with the intent to improve function or design at any time and without notice and is not required to update this documentation to reflect such changes.

This publication does not convey to a purchaser of semiconductor devices described herein any license under the patent rights of Samsung or others.

Samsung makes no warranty, representation, or guarantee regarding the suitability of its products for any particular purpose, nor does Samsung assume any liability arising out of the application or use of any product or circuit and specifically disclaims any and all liability, including without limitation any consequential or incidental damages.

"Typical" parameters can and do vary in different applications. All operating parameters, including "Typicals" must be validated for each customer application by the customer's technical experts.

Samsung products are not designed, intended, or authorized for use as components in systems intended for surgical implant into the body, for other applications intended to support or sustain life, or for any other application in which the failure of the Samsung product could create a situation where personal injury or death may occur.

Should the Buyer purchase or use a Samsung product for any such unintended or unauthorized application, the Buyer shall indemnify and hold Samsung and its officers, employees, subsidiaries, affiliates, and distributors harmless against all claims, costs, damages, expenses, and reasonable attorney fees arising out of, either directly or indirectly, any claim of personal injury or death that may be associated with such unintended or unauthorized use, even if such claim alleges that Samsung was negligent regarding the design or manufacture of said product.

S3F94xx-Series Microcontrollers **Application Notes, Revision 0** **Publication Number:**

© 2009 Samsung Electronics

All rights reserved. No part of this publication may be reproduced, stored in a retrieval system, or transmitted in any form or by any means, electric or mechanical, by photocopying, recording, or otherwise, without the prior written consent of Samsung Electronics.

Samsung Electronics' microcontroller business has been awarded full ISO-14001 certification (BSI Certificate No. FM24653). All semiconductor products are designed and manufactured in accordance with the highest quality standards and objectives.

Samsung Electronics Co., Ltd.
San #24 Nongseo-Lee, Kiheung-Eup
Yongin-City Kyungi-Do, Korea
C.P.O. Box #37, Suwon 449-900

TEL: (02) 760-6530, (0331) 209-6530
FAX: (02) 760-6547
Home-Page URL: [Http://www.samsungsemi.com/](http://www.samsungsemi.com/)

Printed in the Republic of Korea

Table of Contents

Overview.....	1
Features	1
Charging Theory.....	2
Ni-MH Battery	2
Charging Method	2
Theory of Operation.....	2
Charging Curve	2
Termination Methods.....	3
System Implementation	4
S3F94C4 Features.....	4
System Block Diagram & Specification.....	5
HardWare Implementation.....	5
Power Supply	5
LEDs and Switches	5
Buck Converter	5
Measurement Circuit	7
Software implementation	9
Software Flowchart	9
Source Code Files	10
Charging test	15
Test Environment.....	15
Test Method.....	15
Test Result	16
Appendix.....	18
S3F94C4 Features	18
Schematic.....	19
Source Code.....	20
Main.c	20
Charge.c	25
Operation.c	27
Monitor.c	31
Global_Define.h	34

List of Figures

Figure Number	Title	Page Number
1	Charging Curve of Ni-MH Battery	2
2	Diagram of Battery Charger Reference Design	4
3	Buck Converter Switch on	6
4	Buck Converter Switch off	6
5	Voltage Measurement Circuit	7
6	Charging Current Measurement Circuit	8
7	Temperature Measurement Circuit	9
8	Main Function	11
9	Fast Charge Process	12
10	Sup. Charge Process	13
11	Current Regulate Flow in Fast Charge	14
12	Test system configuration	15
13	Charging Voltage & Current Test Waveform	17
14	Pin Assignment Diagram (20-Pin DIP/SOP/SSOP Package)	18
15	Schematic of Reference Design	19

List of Tables

Table Number	Title	Page Number
1	Code File Description.....	10

1. OVERVIEW

Now many portable electrical systems and products use rechargeable batteries as their power supply. The customer has many choices of charging methods, i.e, special power management ICs, MCU controlled, or even logic parts. When one considers safe charging, time-efficiency and low cost factors, the MCU controlled charging method can be used as a recharge solution within many application fields.

This battery charger reference design is based on Ni-MH batteries that fully implements the latest technologies in battery charger designs. The charger can charge battery with full process control: pre-charge the new battery or low voltage battery before fast charge, fast charge Ni-MH batteries with 600mA charging current, supplementary charge after fast charge, keep trickle charge after charge finished.

This battery charger reference design used Samsung highly integrated low cost 8-bit microcontroller S3F94C4, which is ideal for battery charge with timer, PWM, 10-bit ADC. However, it can be implemented using any Samsung microcontroller with A/D converter and PWM output.

Features:

- Fast Charging Algorithm with four charging stages:
 - ✓ Pre-charge with low current when battery voltage is low
 - ✓ Fast charge with voltage and temperature control in constant current
 - ✓ Supplementary charge after fast charge for fully charge
 - ✓ Trickle charge to keep battery fully charged.
- Implements the latest technologies in battery charger designs:
 - ✓ Voltage control: 0 dv or -dv control for fast charge termination
 - ✓ Temperature control: dT/dt, Tmax control for fast charge termination
- High Accuracy measurement with 10-bit A/D converter
- Advanced features for safety and easy-to-use.
 - ✓ Automatic detection of shorted or battery inversed input
 - ✓ Configurable overvoltage, overcurrent and over temperature suspension.
 - ✓ Modular “C” source code.
- 1 bi-color LED (Red/Greed) for on battery to indicate charge status and show error messages.
- Precise power supply soure for MCU system.

2. CHARGING THEORY

2.1 NiMH Battery

Nickel Metal Hydride batteries are the most widely used battery type in new lightweight portable applications (i.e., camera, camcorder, etc.). They have a higher energy density than NiCd. NiMH batteries are damaged from overcharging. It is therefore important to do accurate measurements to terminate the charging at exactly the right time (i.e., fully charge the battery without overcharging). Like NiCd, NiMH batteries are damaged from being inverted.

NiMH has a self-discharge rate of approximately 20% / month. NiMH batteries are charged with constant current.

2.2 Charging Method

2.2.1 Theory of operation

The charging of a battery is made possible by a reversible chemical reaction that restores energy in a chemical system. Depending on the chemicals used, the battery will have certain characteristics. When designing a charger, detailed knowledge of these characteristics is required to avoid damage inflicted by overcharging.

2.2.2 Charging Curve

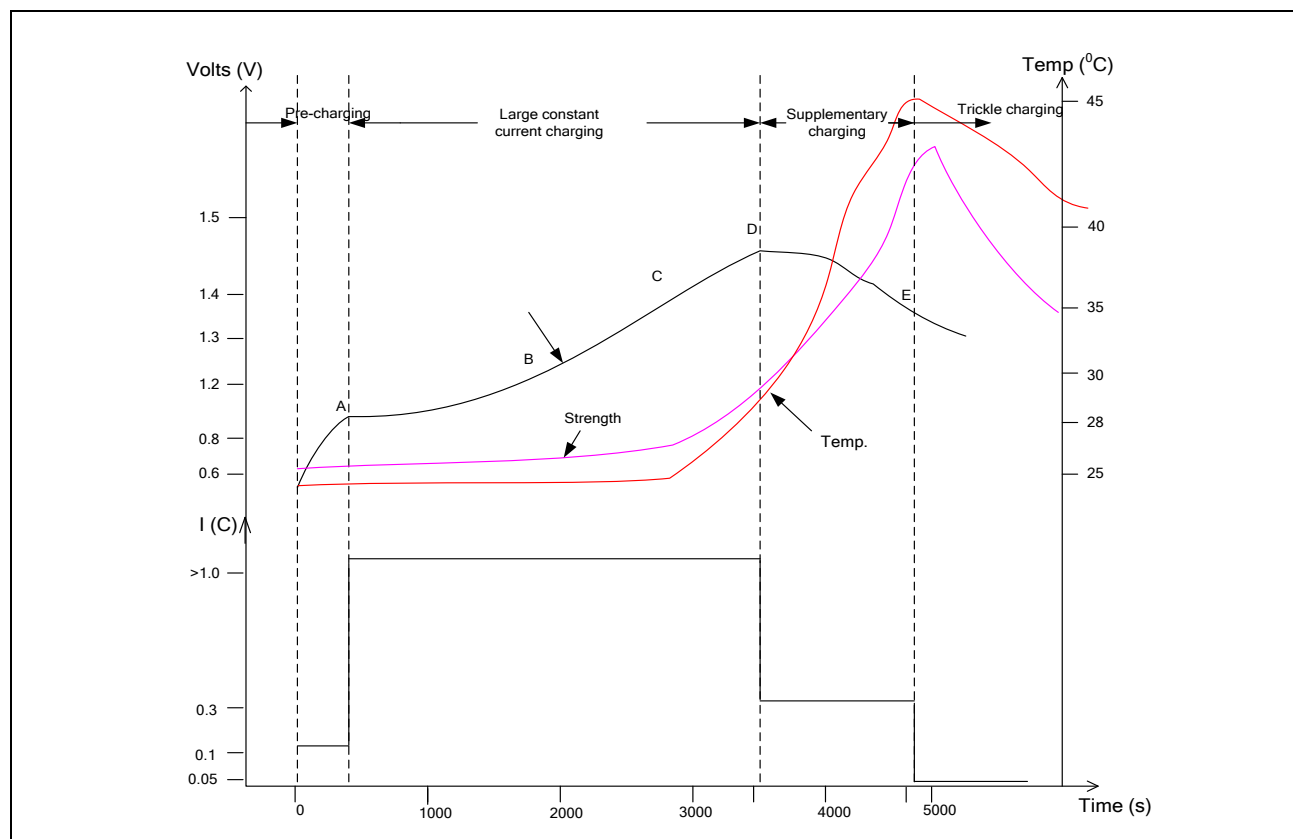

Figure 1. Charging Curve of Ni-MH Battery

If the battery is over-discharged or not used for long time, large current charge can not fully recover the nenergy capacity, so the battery need to be precharged with small current (about $1/30 \sim 1/20C$). This stage called **pre-charge**.

After the voltage of battery rise up, then can enter **fast charge** stage with large current (about $1C$) to charge the battery, the charging current is depended on the capacity of the battery and the charging voltage. The charging current always keeps constant.

When match the fast charge temination condition ($-\Delta V$ or $0 \Delta V$), the fast charge stage terminated, but the battery is not fully charged, so need to be supplementary charged with $0.3C$ current. This stage called **supplementary charge**.

When storage battery, the battery will self-discharge at a rate of $C/30$ to $C/50$, so after supplementary charge, the charger will change to **trickle charge** stage automatically. In trickle charge stage, charger will keep charging the battery for keep the battery in fully charged status.

2.2.3 Termination Methods

This reference design implements the use of voltage drop ($-dV/dt$) as primary termination method, with temperature and absolute voltage as backup. But the hareware supports all of the below mentioned methods.

Time control:

This is one of the simplest ways to measure when to terminate the charging. Normally used as backup termination when fast-charging. Also used as primary termination method in normal charging (14-16h). Applies to all batteries.

Voltage:

Charging is terminated when the voltage rises above a present upper limit. Used in combination with constant current charging. Used as backup termination.

$-dV/dt$ —voltage Drop:

This termination method utilizes the negative derivative of voltage over time, monitoring the voltage drop occurring in some battery types if charging is continued after the battery is fully charged. Commonly used with constant current charging. It's the main termination method used in this reference design.

Temperature:

Absolute temperature can be used as termination method, but is preferred as backup termination method only. Charging should be terminated if the temperature rises above the operating temperature limit of Ni-MH batteries. It also used as backup method.

dT/dt – Temperature Rise:

The derivative of temperature over time can be used as termination method when fast charging. Normally, when the temperature increase $1^\circ C$ /minute, charging should be terminated as quickly as possible.

3. SYSTEM IMPLEMENTATION

3.1 S3F94C4 Features

This reference design using Samsung S3F94C4 as main microcontroller. S3F94C4 is a 20-pin microcontroller, with 4-K bytes flash ROM, and 208 Bytes RAM. It has a 8-bit timer, 10-bit resolution ADC with 9 channels, and 8-bit PWM.

These all features makes S3F94C4 is very suitable for battery charger application: 10-bit ADC for voltage and current measurement; 8-bit PWM for charging current & voltage control , 8-bit timer for system time control. Internal RC OSC is help for those application (like battery charger) that do not need high system frequency.

3.2 System Block Diagram & Specification

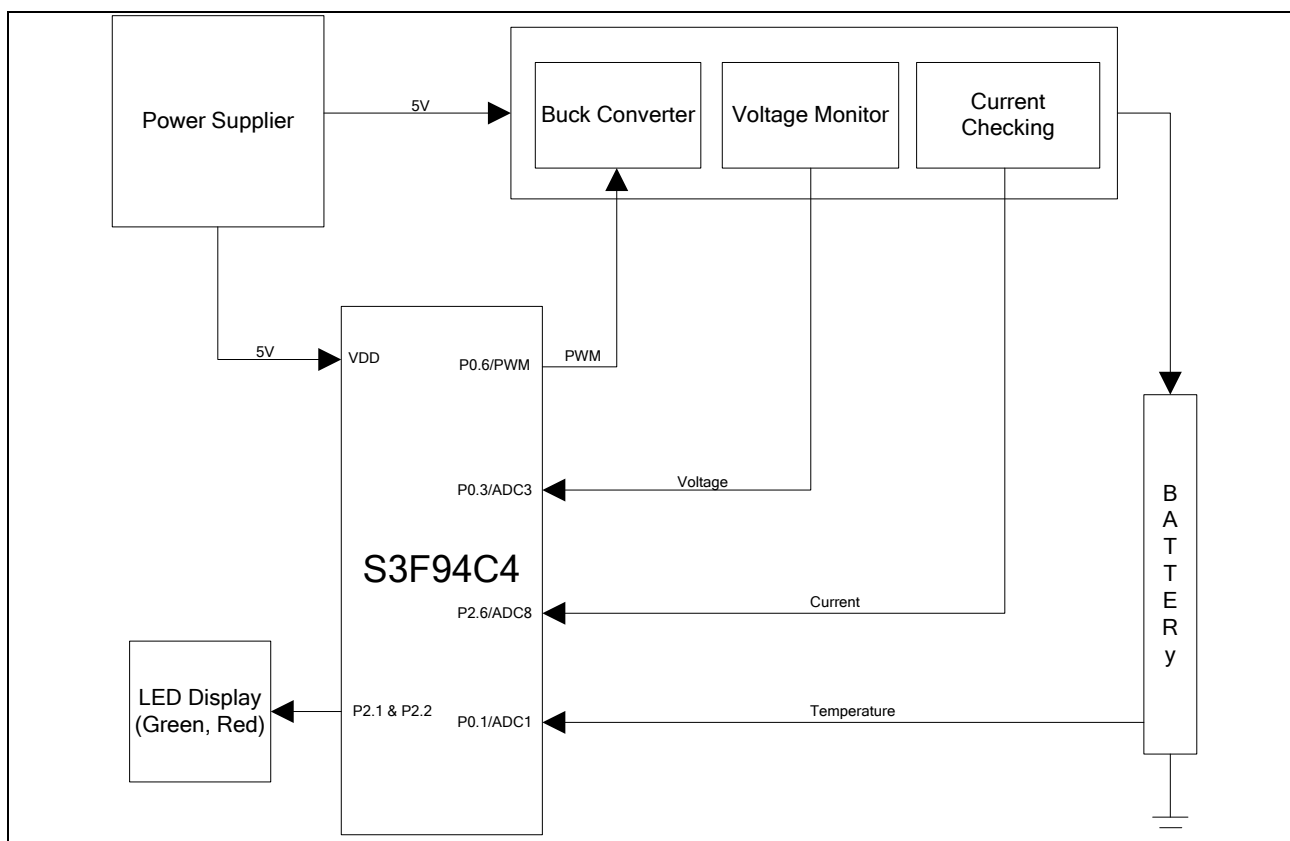

Figure 2. Diagram of Battery Charger Reference Design

- Input to MCU(three ADC input signal)
 - ✓ Voltage monitor for battery fully charged condition check and battery state check
 - ✓ Current check for constant charging current control.
 - ✓ Temperature monitor for battery temperature measurement, charge termination condition

check and battery protection.

- Output from MCU:
 - ✓ PWM output to buck converter circuit for charging current control.
 - ✓ LED output to show charging status and error message with Green and Red LED.

System specification:

- Input voltage: DC 9.0V
- Input current: 100mA
- Output voltage: DC 1.3V
- Output current: 600mA

3.3 Hardware Implementation

3.3.1 Power Supply:

The input voltage is rectified through DC9V-DC5V and then filtered by capacitor. The rectified input voltage is supplied to both the buck converter and to LM7805 voltage regulator. The LM7805 delivers 5V for the microcontroller. The red LED marked “power on” indicates power on.

3.3.2 LEDs and Switches:

This reference design using bi-color LED to indicate the stage of the charge process. If there is no battery insert, the LED is red and blink slowly. If the charging is in processing, the LED is green and blink with different speed in different charge stage. If the battery is fully charged, the LED is green and always on. If there is some error detected, the LED is flicking red. So, from the LED displaying, all of the status of charge process will be acknowledged.

3.3.3 Buck Converter:

The buck charging is usually used in constant current charging. The most economical way to create a constant charge current is to use a buck converter. A buck converter is a switching regulator that uses an inductor as energy storage device.

The buck converter circuit is consist of one P-channel MOSFET switching transistor driven by a bipolar NPN transistor. The switching transistor is connected to an inductor, a diode and a capacitor (see Figure 3).

The charge switch is controlled by PWM. When the switch is on, current will flow as show in Figure 3. The capacitor is charged by the V_{in} through the inductor. When the switch is opened, as show in Figure 4, the inductor will try to maintain its current flow by inducing a voltage, as the current through an inductor can't change instantaneously. The current then flows through the diode and the inductor charges the capacitor, then the cycles repeats itself.

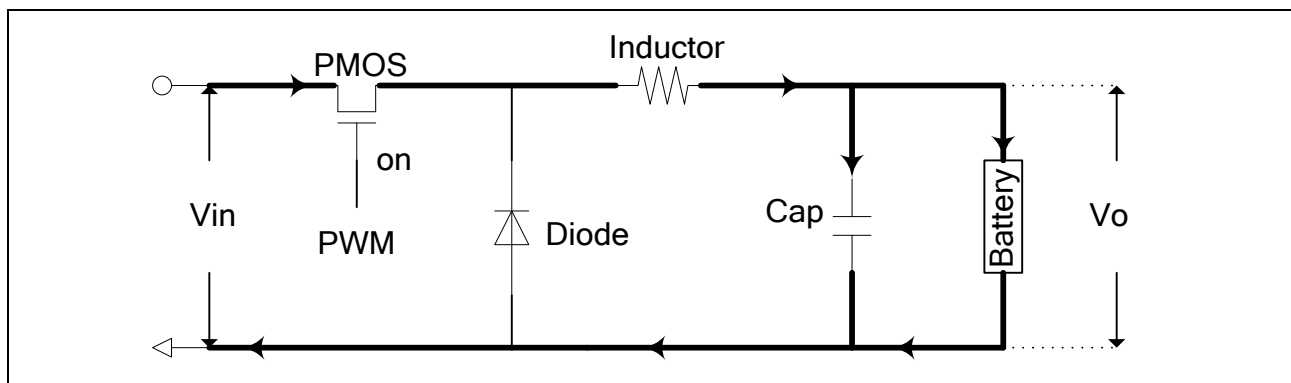

Figure 3 . Buck Converter Switch on

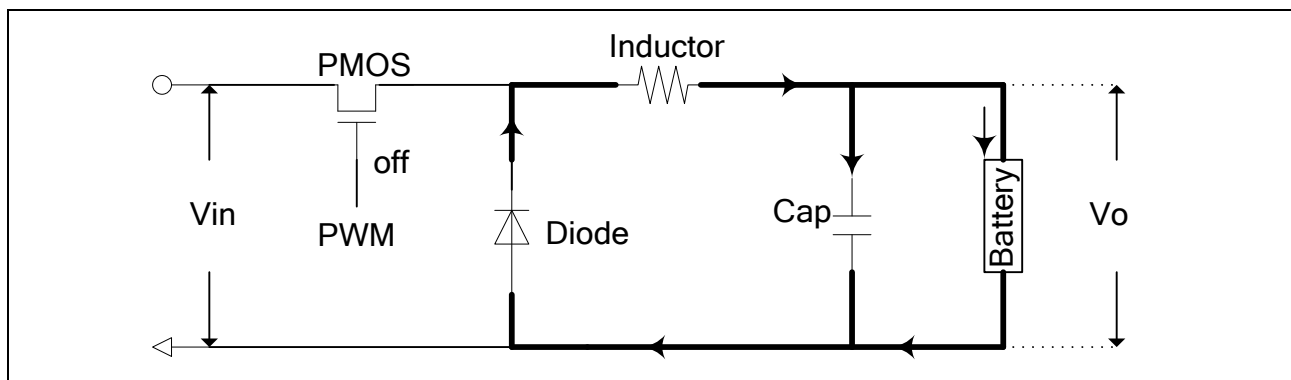

Figure 4. Buck Converter Switch off

If decreases the duty cycle of PWM by shorten the switch 'on' time, the average voltage will decrease. If increases the duty cycle of PWM by longer the switch 'on' time, the average voltage will increase. Therefore, controlling the duty cycles allows us to regulate the charging voltage or the charging current to achieve desired output value. The buck converter is most efficient running on a duty of 50%.

Inductor selection:

$$L = \frac{(V_{IN} - V_{SW} - V_O) \times D}{r \times f \times I_O}$$

Where,

- L: Converter inductor
- V_{IN} : Charger voltage input to switch
- V_{SW} : Voltage loss on switch when switch is on
- V_O : Voltage output
- V_D : Voltage drop on diode when switch is off
- I_O : Current output (the current for constant current charge)
- f: The frequency of the switch.
- D: The duty cycle of the PWM,

$$D = \frac{V_O + V_D}{V_{IN} - V_{SW} + V_D}$$

r: Ripple of current,

$$r = \frac{\Delta I}{I_O}$$

As this equation shows, the higher the PWM switching frequency, the smaller the inductor, enabling lower cost.

Note that the capacitor in this circuit is simply a ripple reducer. In this case, larger is better, as ripple is inversely proportional to the value of this capacitor.

In this reference design, we assume V_{in} is 5V, $V_{sw} = 0.3V$, $V_o = 1.4V$, $I_o = 600$ mA, V_D is 0.5V, the frequency of switch is about 156KHz, and the ripple of current is about 10%, so the L will be 171uH, in this reference design ,we use 220uH inductor as the energy storage device.

Note that if you want to use a higher input voltage, you must use a higher frequency PWM, or you must use a larger value inductor (at a greater cost), so a suitable input voltage is something that must be considered.

3.3.4 Measurement Circuit

Battery voltage:

The charging voltage is monitored using an op-amp to measure the voltage difference between the positive and the negative pole of the battery. The op-amp circuit for measuring the battery voltage is an ordinary differential op-amp circuit. In order to select a suitable measurement range for the charger, need to select suitable scale resistors for the voltage measurement. The voltage op-amp circuit of this reference design is shown in Figure 5. The equation for the output voltage from the op-amp circuit is shown below. The ADC is capable of measuring the voltage range from 0V to 5V, the output range from the op-amp has to be within this range:

$$V_{bat} = \frac{R_{13}}{R_{12}} V_+ + V_-$$

Where,

- V_{bat} : The output voltage from op-amp to microcontroller
- V_+ : The positive pole of the battery
- V_- : The negative pole of the battery
- R_a, R_b : The resistors in the resistor network used to set the gain for the op-amp.

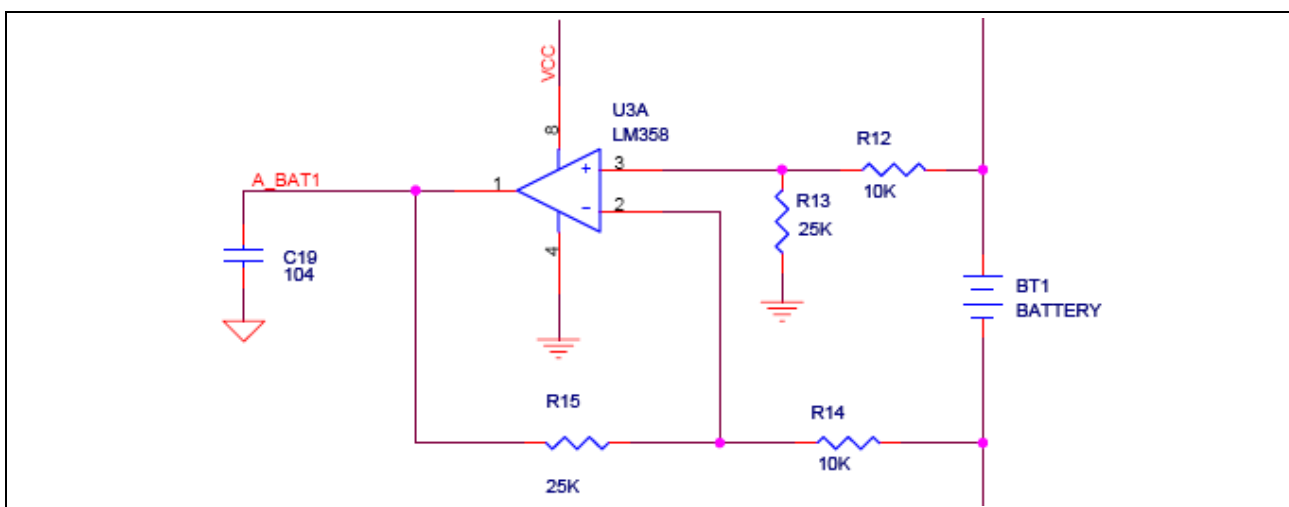

Figure 5. Voltage Measurement Circuit

Charge current:

The detail circuit of charge current measurement is shown in Figure 6. The charge current is measured by sensing the voltage over a 0.050ohm shunt-resistor. This voltage is amplified using an op-amp to improve the accuracy of the measurement before it is fed into the A/D converter.

This voltage is amplified by the factor:

$$1 + \frac{R_{22}}{R_{21}} = 1 + \frac{50000}{470} \approx 51$$

The op-amp output voltage is therefore:

$$V_{ibat} = \left(1 + \frac{R_{22}}{R_{21}}\right) I_{charge} R_{20} = 2.55 \times I_{charge}$$

The maximum charging current that can be measured is:

$$I_{chargeMax} = \frac{V_{ref}}{2.55} = \frac{5}{2.55} = 1.96 \text{ A}$$

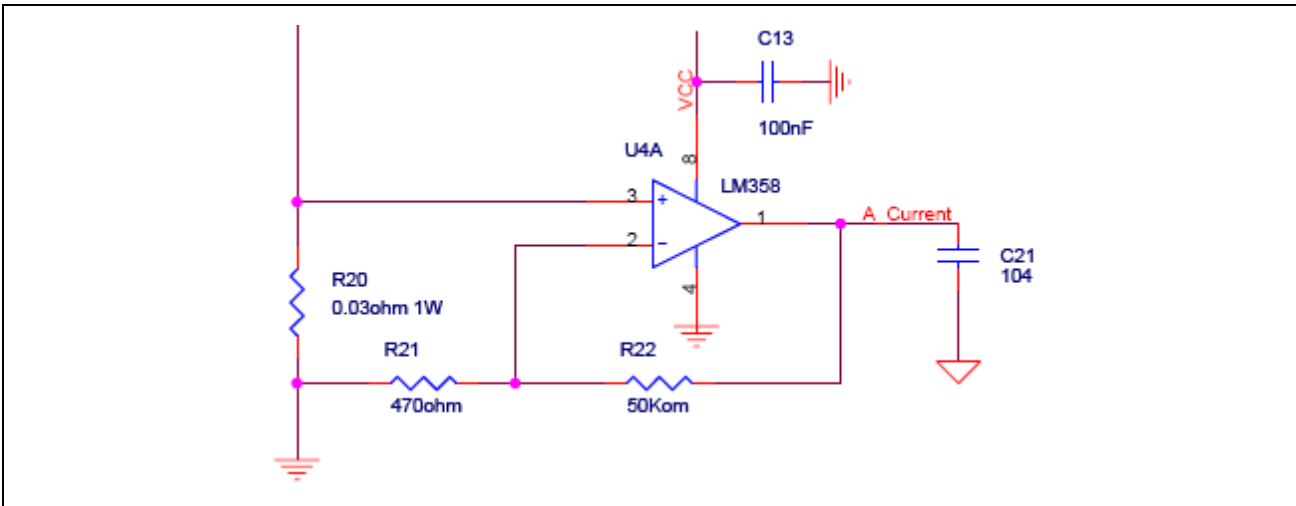

Figure 6. Charging Current Measurement Circuit

Temperature:

Temperature is measured by a negative temperature coefficient (NTC) resistor. The NTC is part of a voltage divider, which is powered by the V_{DD} for microcontroller. The detail circuit is shown in Figure.

7

The temperature is measured:

$$V_{temp} = V_{DD} \times \frac{R_{25}}{(R_{24} + R_{25})}$$

The resistor value is changed according to the temperature, so the V_{temp} is changed accordingly, so, can detect the temperature by check the voltage value of V_{temp} by A/D convert. But, the relationship between the temperature and resistor value is not linear, which makes it difficult to calculate the temperature from the ADC value. In fact, in the real application field, the temperature range of battery is from 10-45°C, in this temperature range, we can treat it as a linear curve approximately.

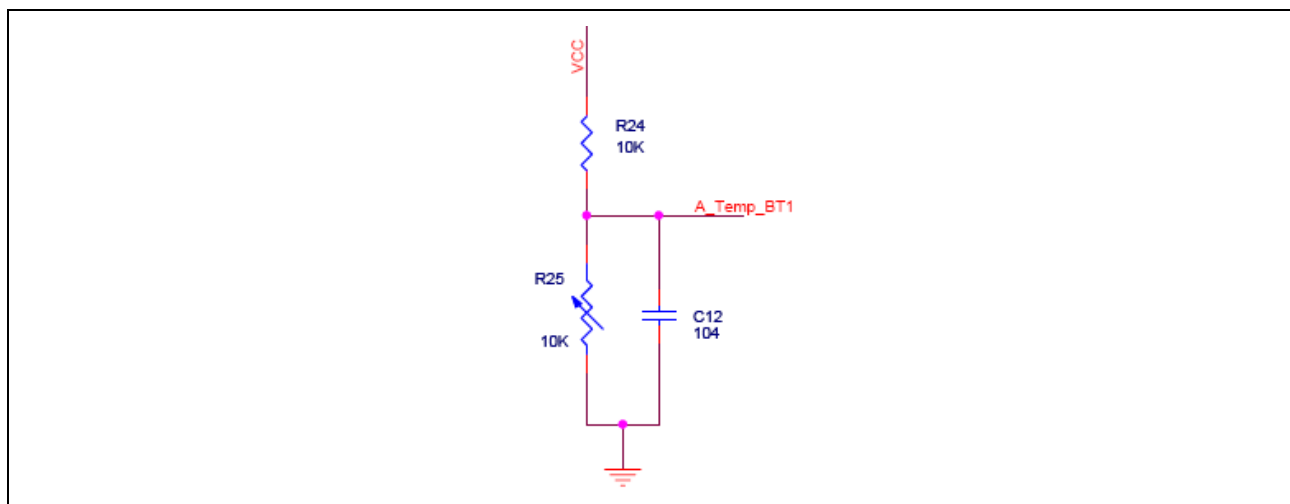

Figure 7. Temperature Measurement Circuit

3.4 Software implementation

3.4.1 Software Flowchart:

The full charge state are divided into four stage: pre-charge, fast-charge, supplementary charge and trickle charge. When a battery is inserted in, which stage is choosed is decided by the battery voltage, and the following charge stage are processed sequentially.

Charge is started if the battery voltage is within the voltage range. If the battery temprature exceed a limited value, the charge will not process. Charge is always terminated with an maximum battery voltage or maximum total-charge time expires.

The normal ways to detect that the battery is fully charged, are the Temperature Rise (dT/dt) and the voltage drop ($-dV/dt$) methods. Therefore, a sample is taken every minute for the temperature and every 2 seconds of the voltage. The values are compared to the sample taken one minute/second ago. In case the battery is fully charged, the charge status is autotomatically changed to trickle-charge.

The trickle-charge excutes in a loop when the overall charge time exceeded the large current charge time limitation, or the voltage or temprature overflow the maximum value.

In this reference design, the charger can charge two battery at the same time. These two battery have same charge mechanism and can be charged simutanenous, so, in the sofeware, there only one battery charge process for demonstration, and it can be easily expanded to support charge two batteries.

3.4.2 Source Code Files

The software is written in C language. The source code include following files:

Table 1. Code File Description

File Name	Description	Remark
Main.C	The main function of the code, and the system initialization function.	
Global_define.h	Global variables declaration; Constant define; Marco definition	
Charge.c	The charge function of each charge stage	
Charge.h	Head file for Charge.c; function declaration.	
Operation.c	Execution funtion of the four charge stage.	
Operation.h	Head file for operation.c; function declaration	
Monitor.c	Battery Voltage, charge current , temperature measurement function. Mianly are ADC functions	
Monitor.h	Head file for Monitor.c: function declaration	
ioS3F94C4.h	Register difinition and interrupt vectors declaration for S3F94C4.	

Main.c:

This module include the main function of the system, the system initialization function and interrupt handling routines.

In the “Sys_init” routine, all low-level initialization are done. The I/O ports and PWM, timer block are initialized. In the “System_Clear” routine, the system global variables are clear to there initial value for charge another battery.

The main function “main” is the basic function of the system, the software flowchart is realized in main function, and the major part of the main function is a dealy loop keep running in front of the software platform after chip reset, that check the battery voltage and take execution according to the battery voltage and charge state.

Global_define.h:

In this module, include the definition of the charge state, constant related to the system parameters, and the declaration of global variables. This module is included by each module for common definition and declaration.

ioS3F94C4.h:

This module include the register definintion and interrupt declaration of S3F94C4.

Main flow chart

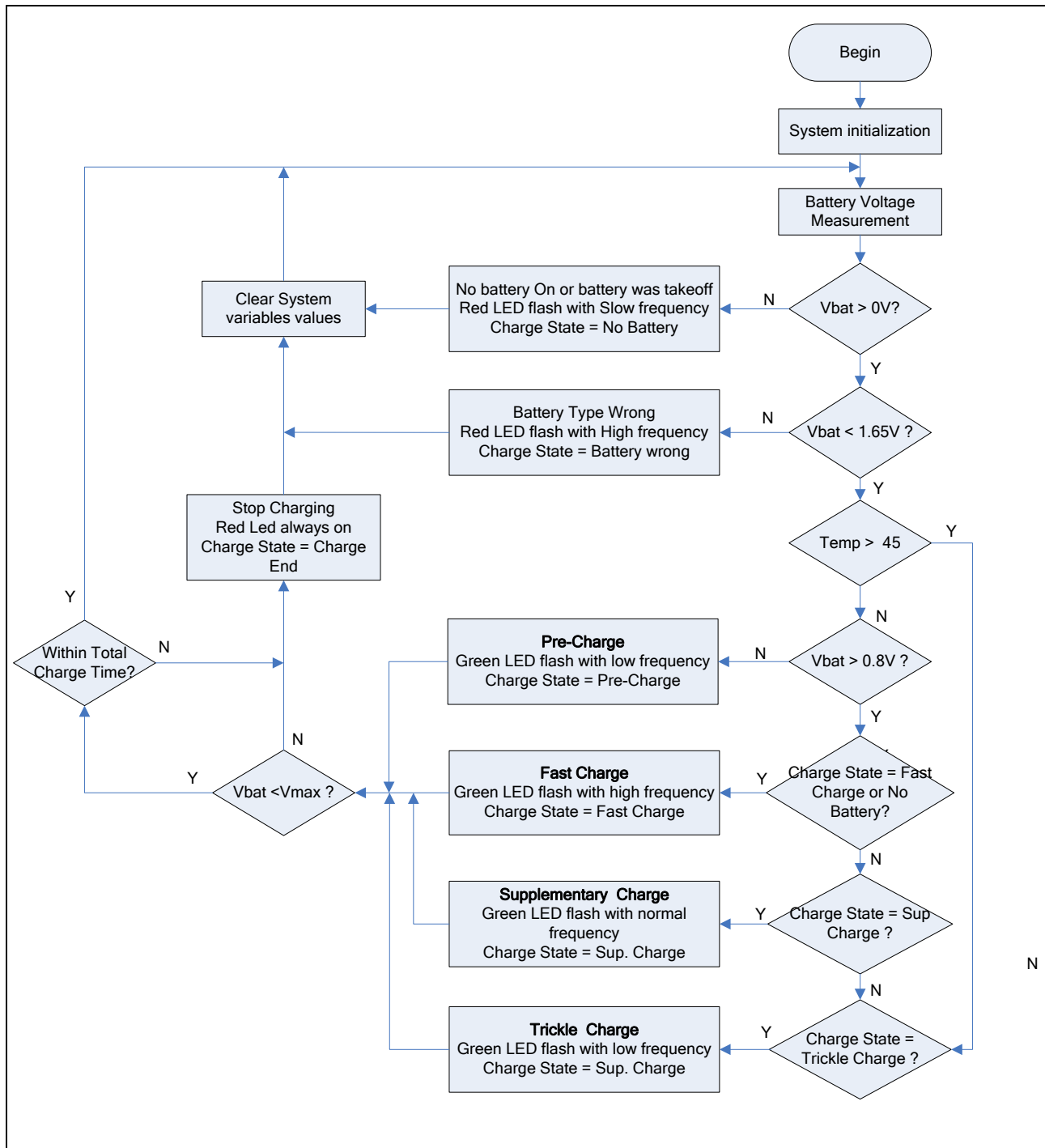

Figure 8. Main Function.

Charge.c:

This module Include the functions for each charge stage. These functions are part of the main loop, and called by main function.

Ni-MH battery is charged by constant current, in fast charge stage, the charge current is set to about 600mA. The charge is terminated by the Temperature Rise(dT/dt) and the Voltage Drop(-dV/dt) methods. Maximum charge voltage and maximum charge time are used as backup terminations.

Fast charge process:

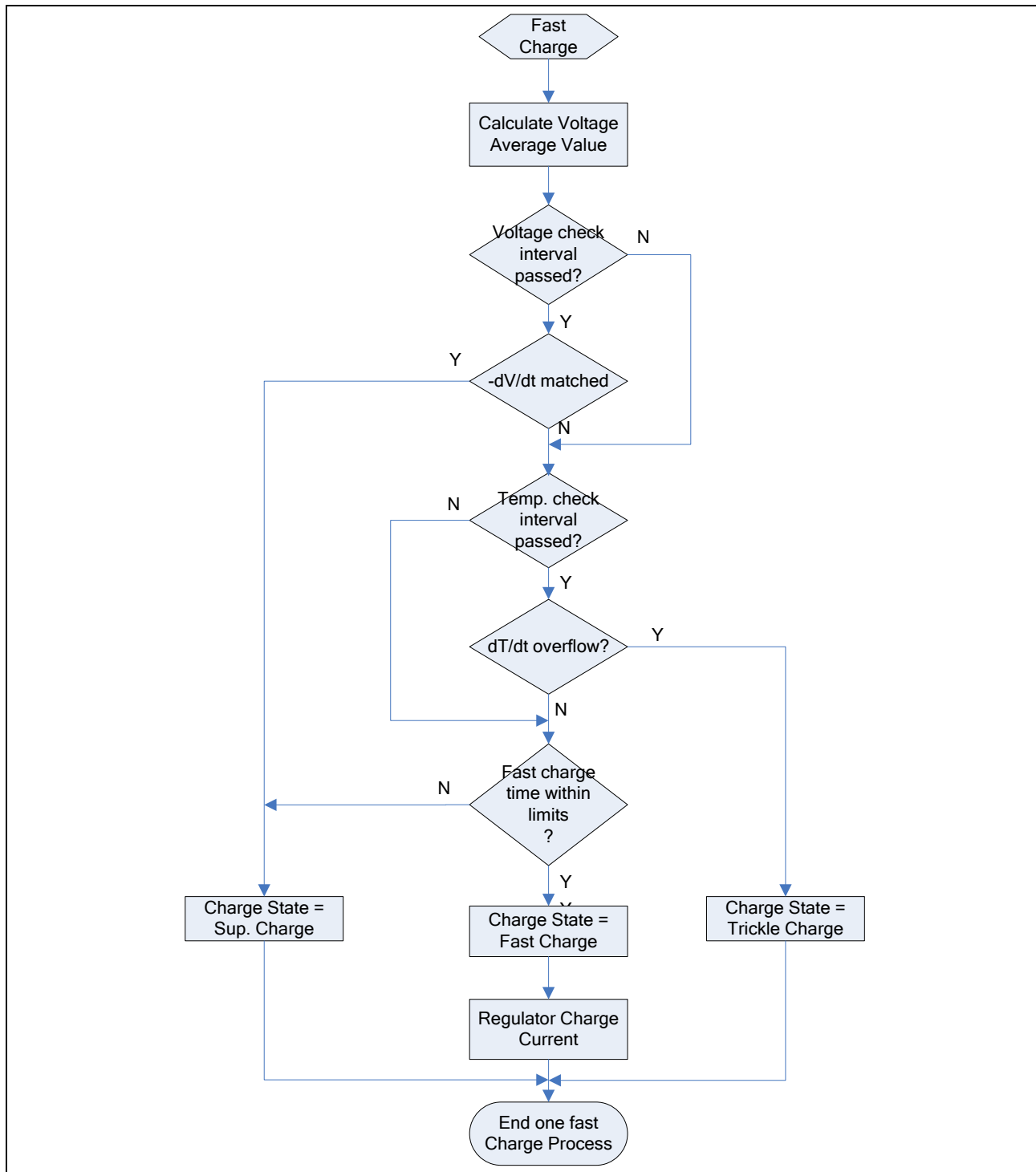

Figure 9. Fast Charge Process.

In case the battery is fully charged the charge stage is automatically changed to supplementary charge, causing the program to execute the supplementary charge function.

Supplementary charge is also charge by constant current, and the charge is terminated by Temperature Drop (dT/dt) or Maximum supplementary charge time. In case of the termination condition matched, the charge status changed to trickle charge automatically.

Supplementary charge process:

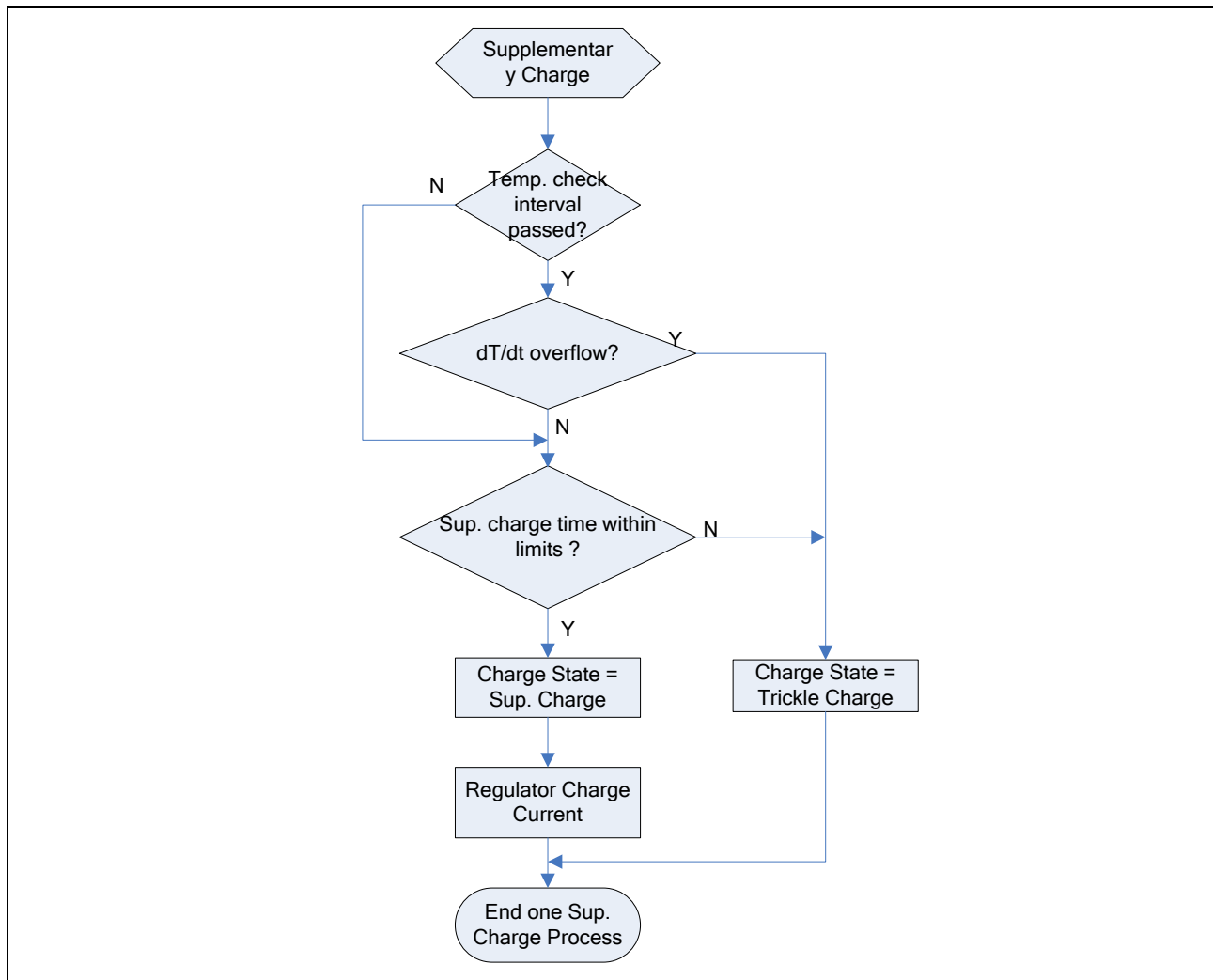

Figure 10. Sup. Charge Process.

Monitor.c:

This module mainly include the measurement functions of battery voltage, charge current and battery temperature. And the charge termination condition check functions are also included.

Operation.c:

This module include the charge current regulator of each charge state, mainly the PWM duty width control according the required constant charge current. And the PWM operation functions and the system message display function are also included in this module. These four stage have similar control algorithm, so, we take the fast charge as example:

Current Regulator Flow:

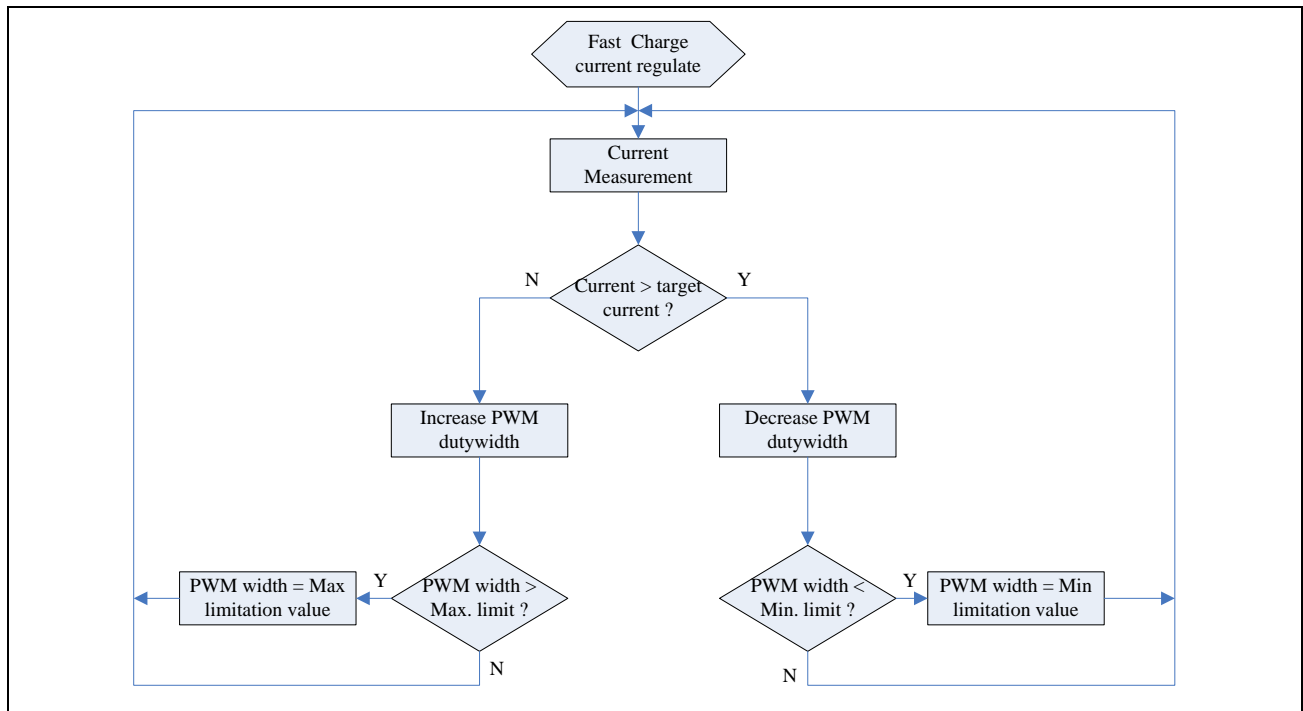

Figure 11. Current Regulate Flow in Fast Charge.

4. Charging test

Test Environment

- Temperature: 25°C
- Battery: 1300mAh Ni-MH battery
- Power Supply: Adapter (output: 9V, max 1.0A)
- Instruments:

Test Method

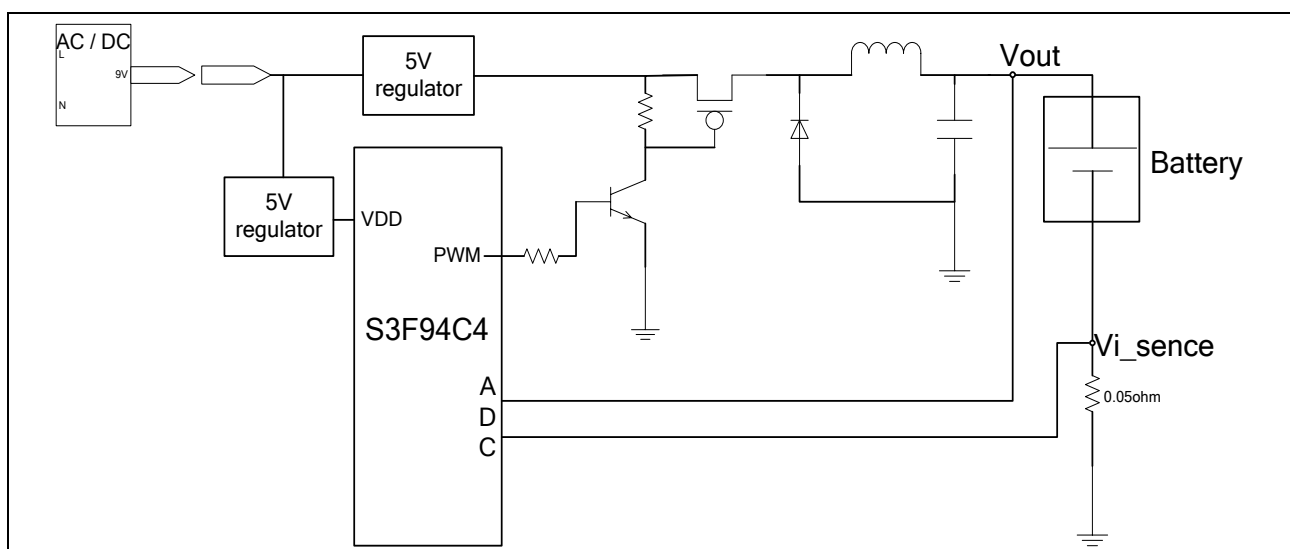

Figure 12. Test system configuration.

Detected value:

$$V_{out} = V_{bat} + V_{i_sense}$$

$$I_{out} = V_{i_sense} / 0.05$$

As shown in Figure 12, during the charging process, watch the voltage at the test points of V_{out} and V_{i_sense} , using two multimeters to get the charging voltage, then calculate the charging current by $V_{i_sense} / 0.05$.

At the beginning of the charging process, record the data every 60 seconds. When the charging current and voltage become stable, the test interval becomes longer (every 4 minutes).

Test Result

- Fast charging time: 56 minutes
- Constant current of fast charge: 610mA
- Fast charge end voltage: 1.408V
- Supplementary charge current: 120mA
- Supplementary charge end voltage: 1.396V
- End charge voltage: 1.396V

These results may vary from battery to battery because of the variation of their physical characteristics. The original voltage of the battery also has an impact on the results. However, the specification is easily achieved. The results are shown in following test diagrams.

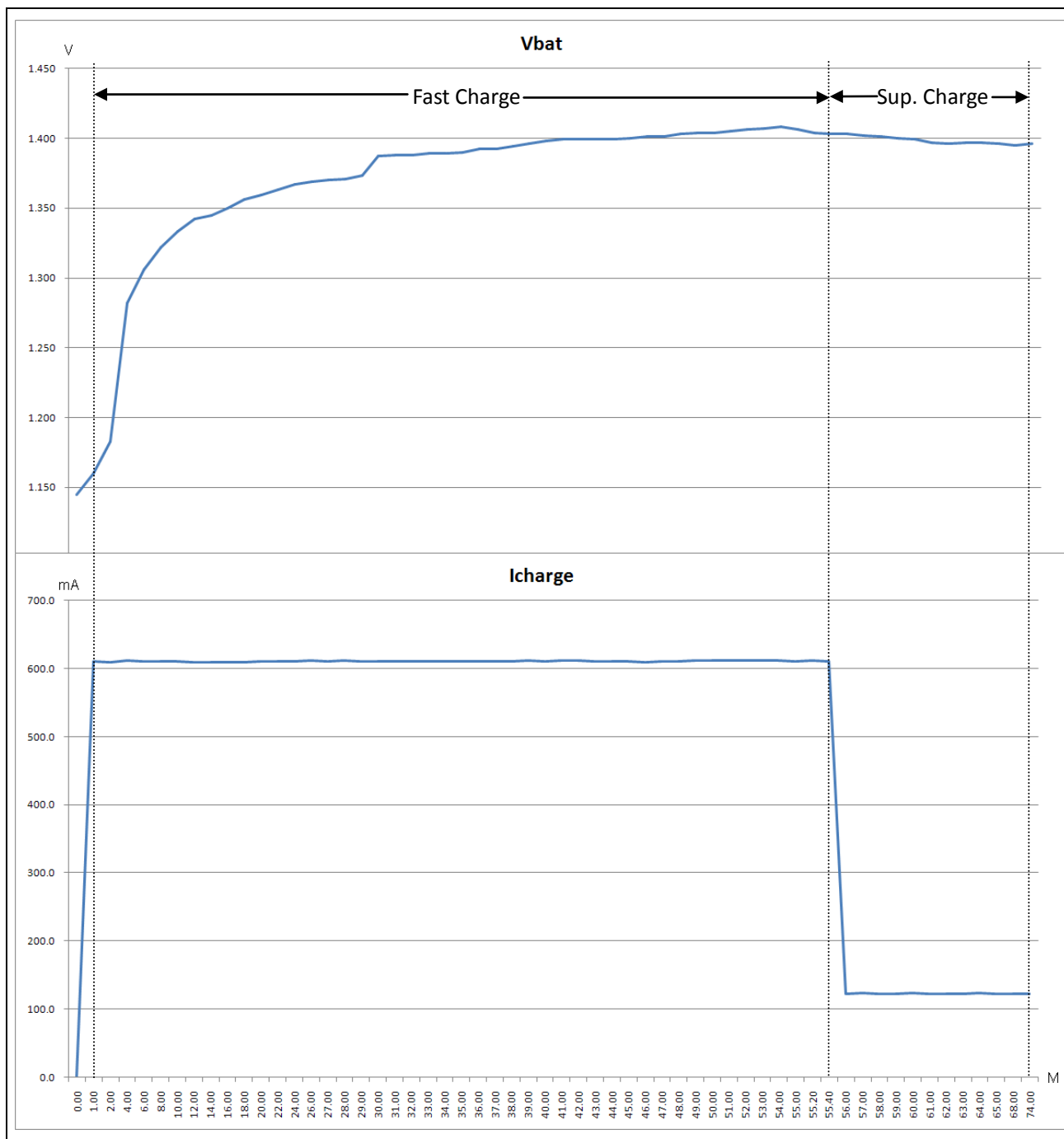

Figure 13. Charging Voltage & Current Test Waveform.

5. Appendix

S3F94C4 Features:

Memory

- 4-Kbyte internal multi-time program Full-Flash memory
- 208-byte general-purpose register area

General I/O

- Three I/O ports (Max 18 pins)
- Bit programmable ports

1-ch Three Modes High-speed PWM

- 6-bit base + 2-bit extension
- 8-bit base + 6-bit extension
- 6-bit base + 6-bit extension

Timer/Counters

- One 8-bit basic timer for watchdog function
- One 8-bit timer/counter with time interval modes

A/D Converter

- Nine analog input pins (MAX)
- 10-bit conversion resolution

Built-in RESET Circuit (LVR)

- Low-Voltage check to make system reset
- $V_{LVR} = 1.9/2.3/3.0/3.6/3.9$ V (by smart option)

Operating Temperature Range

- -40°C to $+85^{\circ}\text{C}$

Operating Voltage Range

- 1.8 V to 5.5 V @ 1-4M Hz(LVR disable)
- LVR to 5.5V @ 1-4M Hz(LVR enable)
- 2.7 V to 5.5V @ 1-10M Hz

Package Types

- S3F94C4:
 - 20-DIP-300A
 - 20-SOP-375
 - 20-SSOP-225
 - 16-DIP-300A
 - 16-SOP-225
 - 16-TSSOP-BD44

Pin Assignment:

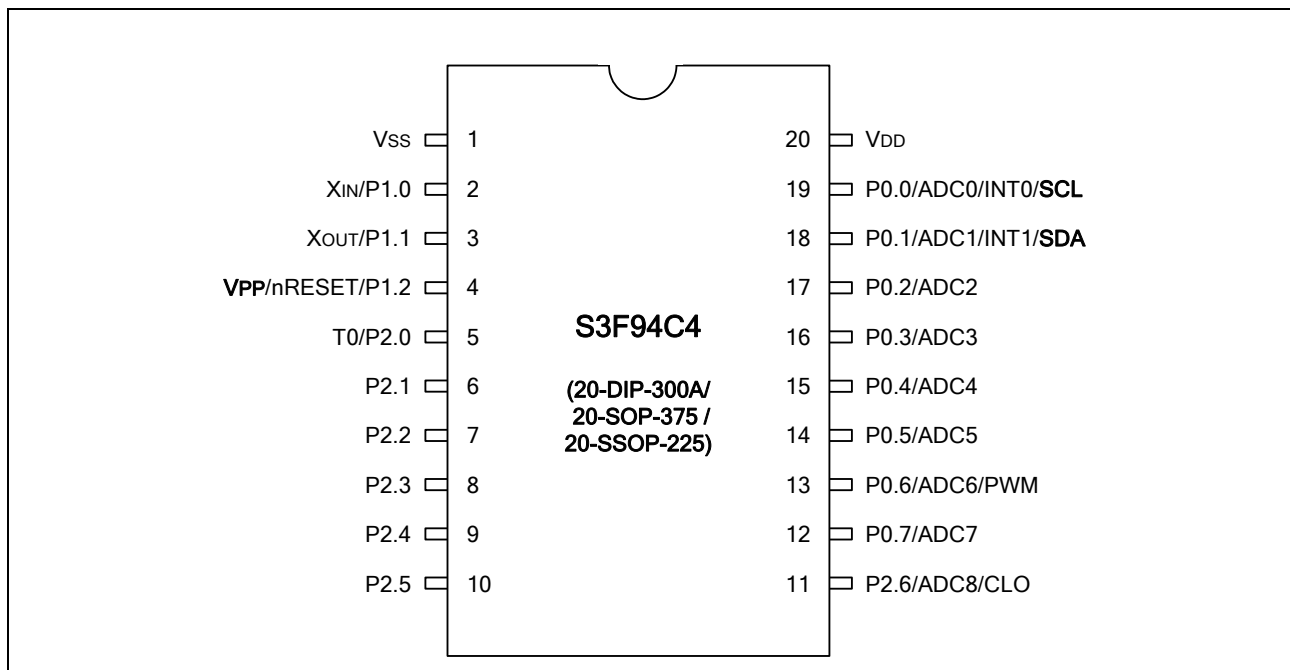

Figure 14. Pin Assignment Diagram (20-Pin DIP/SOP/SSOP Package)

Source Code

```

/**
 * @file name   Main.c
 * @description Main functions for Battery charger code
 *
 *             XTAL = 10MHz
 *
 * @author     Li Baoke(86-571-86726288 EXT.8103, baoke.li@samsung.com)
 * @version    Preliminary 0.0
 * @historyHistory type - NEW/MODify/ADD/DElete
 *
 * -----
 * |ver type when      who                what
 * |---+---+-----+-----+-----
 * |0.0 NEW 2008-03-06  Li Baoke          Creation
 * -----
 *
 * @see       IAR C Compiler Tool
 */
/*****
***** INCLUDES *****/
/*****
#include "Globle_Define.h"
#include "Charge.h"
#include "Operation.h"
#include "Monitor.h"
/*****
***** SMART OPTION *****/
/*****
/* Smart option 3CH
   Must be initialized to 0x00 */
__root __code const unsigned char SMT1 @ 0x3C = 0x00;
/* Smart option 3DH
   Must be initialized to 0x00 */
__root __code const unsigned char SMT2 @ 0x3D = 0x00;
/* Smart option 3EH
   0xFF -> LVR Enable (default)
   0x7F -> LVR Disable */
__root __code const unsigned char SMT3 @ 0x3E = 0x7F;
/* Smart option 3FH
   0xFF -> Internal RC 3.2MHz (default)
   0xFE -> Internal RC 0.5MHz
   0xFD -> 0.5MHzExternal RC
   0xFC -> External Crystal */
__root __code const unsigned char SMT4 @ 0x3F = 0xFC;
/*****
*****Global Variable definition*****
*****
/*-----
 *
 *             Battery  related variables
 *-----*/
unsigned char Bat1State = 0; //battery 1 state
/* voltage monitor related */
unsigned int  Bat1Volts = 0; //Battery 1 voltage ADC convert result;
unsigned int  Bat1VoltsArray[9]={0,0,0,0,0,0,0,0,0}; //voltage sample array,last one is average value.
unsigned int  Bat1AvgArray[9] = {0,0,0,0,0,0,0,0,0}; //voltage average array, last one is average value.
/* temperature related */
unsigned int  Bat1TempADC = 0; //battery 1 temperature ADC result
unsigned int  Bat1Temp = 0; //battery 1 temperature
unsigned int  Bat1PreTemp = 0; //battery 1 pre temp data
unsigned int  Bat1TempChkIntv = 0; //battery temperature checking interval
/* time control related parameters (time = interval * counter) */
unsigned int  Bat1TimeTotalInterval = 0; //battery 1 total charge time interval
unsigned char Bat1TimeTotalCounter = 0; //battery 1 total charge time counter
unsigned int  Bat1TimeFastInterval = 0; //battery 1 fast charge time interval
unsigned char Bat1TimeFastCounter = 0; //battery 1 fast charge time counter

```

```

unsigned int  Bat1TimeSupInterval = 0;           //battery 1 Sup. charge time interval
unsigned char Bat1TimeSupCounter = 0;           //battery 1 Sup. charging time counter
/*Termination condition check related variables*/
unsigned char Bat1VoltChkFlag =0;              //voltage checking flag:1-start check; 0- no check
unsigned int  Bat1VoltChkIntv = 0;             // battery 1 voltage checking interval
unsigned int  PreVolts = 0;                    //voltage check value: pre-tested value
unsigned int  PreVolts1 = 0;                   //voltage check value: pre-tested value 1
unsigned int  VoltDropCnt = 0;                  //counter of voltage drop (Prevoltage - Vcheck >= 1)
unsigned char VoltDropCnt1 = 0;                //counter of voltage drop every 1 minute.
unsigned int  Bat1AvgMax = 0;                  //Max value of the average voltage
unsigned int  Bat1AvgMin = 790;                //Min value of the average voltage
unsigned int  VoltAvgDropCnt = 0;              //counter of Vave <= Vmax-4
unsigned char VoltAvgDropCnt1 = 0;            //counter of Vave <= Vmax-3
unsigned int  DvStartTestTime = 0;            //-dv check delay time
/*-----
*                   common variables
*-----*/
unsigned char PWMWidth = 80;                   //Fast charging  pwm duty width
unsigned char PWMRunFlag = 0;                  //PWM run or stop flag:0 == init; 1== strat run; 2== stop run
unsigned int  ChargingCurrent = 0;             //Charging current convert result.
unsigned char TOMatchCounter = 0;              // TO interrupt timing counter
/*****
*****  FUNCTIONS  *****/
*****/
/*
** Main function
*/
void main(void)
{
  __enable_interrupt();
  __disable_interrupt(); //Disable global interrupt
  SP=0xC0; //stack point setting @ 0xC0
  Sys_init(); //System initialization: board environment setting
  __enable_interrupt(); //Enable global interrupt
  while(1)
  {
    ChargingCurrent = Charging_Current_Monitor();
    ChargingCurrent = Charging_Current_Monitor() + CURRENT_AMP_COMPENSATE;
    /*----- battery take off check-----*/
    if ( ( (Bat1State == BATTERY_FAST_CHARGING) ||
           (Bat1State == BATTERY_SUP_CHARGING) ||
           (Bat1State == BATTERY_TRICKLE_CHARGING) ) &&
         (ChargingCurrent <= CHG_CURRENT_MIN) ) //take off in charging process
    {
      Bat1State = BATTERY_CHARGING_END;
      Show_BAT1_State(BATTERY_CHARGING_END); //show message
      System_Clear();
      delay(65500); //wait for capacitor discharge
      delay(65500);
      delay(65500);
      delay(65500);
      delay(65500);
      delay(65500);
      delay(65500);
      Bat1State = NO_BATTERY;
    }
    Bat1Volts = BAT1_V_Monitor(); //ADC result = ((2.5Vbat+) + Vbat-)*1024/5
    Bat1Volts += BAT1_V_Monitor();
    Bat1Volts += BAT1_V_Monitor();
    Bat1Volts = Bat1Volts / 3;
    if(Bat1Volts >= BAT_DETECTOR_VOLTS)
      Bat1Volts -= (ChargingCurrent/CURRENT_AMP_GAIN);
    /*----- battery on check-----*/
    if( Bat1Volts <= BAT_DETECTOR_VOLTS ) //if Vbat <0.1V,no battery insert
    {
      Bat1State = NO_BATTERY;
      Show_BAT1_State(NO_BATTERY); //show message
    }
  }
}

```

```

        System_Clear();                // clear global variables to init. values
    }
    /*-----Decide DV check delay time-----*/
    if( (Bat1Volts > BAT_DETECTOR_VOLTS) && (Bat1State == NO_BATTERY))
    {
        if(Bat1State > VOLTS_OF_INIT_DLY_1)
            DvStartTestTime = INIT_CHECK_DLY_1;
        if(Bat1State > VOLTS_OF_INIT_DLY_2)
            DvStartTestTime = INIT_CHECK_DLY_2;
        if(Bat1State > VOLTS_OF_INIT_DLY_2)
            DvStartTestTime = INIT_CHECK_DLY_3;
    }
    /*----- battery type check-----*/
    if( Bat1Volts  >= BAT_MAX_VOLTS)                //if Vbat > 1.5V, battery tpye wrong or charging finished
    {
        if( (Bat1State != BATTERY_TYPE_ERROR) &&
            (Bat1State != NO_BATTERY) )           //Vmax Control: if Vbat > Vmax, enter trickle charge
        {
            Bat1State = BATTERY_TRICKLE_CHARGING;
        } else {
            Bat1State = BATTERY_TYPE_ERROR;
        }
    }
    /*----- battery temperature monitor-----*/
    Max_Temp_Detect();
    /****** Pre-charge *****/
    if( (Bat1Volts > BAT_DETECTOR_VOLTS) &&
        (Bat1Volts <= BAT_PREEND_VOLTS) &&
        (Bat1State <= BATTERY_PRE_CHARGING ) )
    {
        Bat1State = BATTERY_PRE_CHARGING;
        Battery_Pre_Charge();
    }
    /****** Fast charge *****/
    if( ((Bat1Volts > BAT_PREEND_VOLTS) &&
        (Bat1Volts <= BAT_MAX_VOLTS)) &&
        (Bat1State <= BATTERY_FAST_CHARGING) )
    {
        Fast_Charge();
    }
    /****** supplementary charge *****/
    if( ((Bat1Volts > BAT_PREEND_VOLTS) &&
        (Bat1Volts <= BAT_MAX_VOLTS)) &&
        (Bat1State == BATTERY_SUP_CHARGING) )
    {
        Sup_Charge();
    }
    /****** trickle charge *****/
    if(Bat1State == BATTERY_TRICKLE_CHARGING)
    {
        Bat1State = BATTERY_TRICKLE_CHARGING;
        Battery_TRK_Charge();
    }
    /*----- total charging time check -----*/
    if( (PWMRUNFlag == CHARGING_RUN) && (Bat1State != BATTERY_TRICKLE_CHARGING))
    {
        Max_ChargeTime_Detect();
    }
    Show_BAT1_State(Bat1State);
}
}
/*
** System and peripheral registers initialization.
*/
void Sys_init(void)
{

```

```

/*System Control Registers Initialization*/
BTCN = 0xA3; //disbale WachtDog, clear basic timer couer
CLKCON = 0x0C; //enable IRQ wake up; Fcpu = Fosc/1
/*I/O Ports Control Registers Initialization*/
POCONH = 0xDB; //11011011b
//P0.7 ADC input --- battery 2 temperature monitor;
//P0.6 PWM --- Bulk circuit control signal; set as output in init stage.
//P0.5 Output --- Battery 1 charing control;
//P0.4 ADC input --- Battery 2 voltage monitor;
POCONL = 0xEE; // 11101110b
//P0.3 ADC input --- battery 1 voltage monitor;
//P0.2 Output --- Battery 2 charging control;
//P0.1 ADC input --- Battery 1 temperature monitor;
//P0.0 Oupput --- Battery 1 Discharging control;
POPND = 0x00; //no external interrupt --- disable external interrput
P0 = 0x00; //Port 0 no output;
P1CON = 0x0A; //00001010b
// P1.1-0 set to output to prevent current consumption
P1 = 0x00; //Port1 not used.
P2CONH = 0x32; //00110010b
//P2.6 ADC input --- Charing current moniotr;
//P2.5 Input --- Function selection signal 2
//P2.4 Output --- Green Led for battery 2
P2CONL = 0xA8; //10101000b
//P2.3 Output --- Red Led for battery 2
//P2.2 output --- Green Led for battery 1
//P2.1 output --- Red Led for battery 1
//P2.0 input --- Function selection signal 1
P2 = 0x00; // P2.4-.1 output low (LED trun off).
/* Peripheral Control Registers Initialization */
TOCON = 0x02; //00000010b
//Clock = fosc/4096
//clear counter;enable interrupt; clear pending bit;
//inteval: 122 cycles. 50ms@10MHz system clock.
TODATA = 122; //PWM initialize: 11010000b
PWMCON = 0xD0; //Clock = fosc/1;
//Stop run at first;
//disable interrupt; clear pending bit;
PWMDATA = 0x00; //base mode
ADCON = 0x94; //ADC module initialize: 10010100
//channel select: connect to GND
//clock = fosc/4 = 2.5MHz@ fosc = 10MHz
//Stop convert

/* Global Variable initialize */
Bat1State = NO_BATTERY; //default: no battery after start run...
}
void System_Clear()
{
    unsigned char i;
    PWMCON &= 0xFB;
    //set P0.6 as output :
    P0CONH &= 0xCF; //&11101111B (bit5 = 0)
    P0CONH |= 0x20; //|00100000B (bit4 = 1)
    P0_bit.b6 = 0; //output low to stop charging Bat1TimeTotalInterval = 0;
    Bat1TimeTotalCounter = 0;
    Bat1TimeFastInterval = 0;
    Bat1TimeFastCounter = 0;
    Bat1TimeSupInterval = 0;
    Bat1TimeSupCounter = 0;
    Bat1VoltChkIntv = 0;
    Bat1VoltChkFlag = 0;
    for(i=0; i<8;i++)
        Bat1VoltsArray[i] = 0;
    for(i=0; i<8;i++)
        Bat1AvgArray[i] = 0;
    PreVolts = 0;
    PreVolts1 = 0;
}

```

```

VoltDropCnt = 0;
VoltDropCnt1 = 0;
Bat1AvgMax = 0;
Bat1AvgMin = 790;
VoltAvgDropCnt = 0;
VoltAvgDropCnt1 = 0;
DvStartTestTime = 0;

Bat1TempADC = 0;
Bat1Temp = 0;
Bat1PreTemp = 0;
Bat1TempChkIntv = 0;

PWMWidth = 0;
PWMRunFlag = 0;
ChargingCurrent = 0;
}
/*
** Delay function
*/
void delay(unsigned int nLoop_CNT)
{
    int i;
    for(i=0;i<=nLoop_CNT;i++)
        __no_operation();
}
/*****
*****Interrupt service routine*****
*****/
/*
** Interrupt service routine (software polling sequence decide interrupt priority.)
*/
#pragma vector=__P00_vector
__interrupt void ISR_Processing(void)
{
    if(T0CON_bit.PND == 1)
    {
        TOMatchCounter++; //match interval: 50ms
        if( (PWMRunFlag ==CHARGING_RUN) && (Bat1State != BATTERY_TRICKLE_CHARGING) )
        {
            Bat1TimeTotalInterval++;
        }
        if( (PWMRunFlag ==CHARGING_RUN) && ( Bat1State == BATTERY_FAST_CHARGING) )
        {
            Bat1TimeFastInterval++;
            //Bat1TempChkIntv++;
            if(Bat1VoltChkFlag == 1)
            {
                Bat1VoltChkIntv++;
            }
        }
        if( (PWMRunFlag ==CHARGING_RUN) && (Bat1State == BATTERY_SUP_CHARGING))
        {
            Bat1TimeSupInterval++;
            //Bat1TempChkIntv++;
        }
    }
    PWMCON_bit.PND = 0;
    TOCON_bit.PND = 0; //clear timer0 pending bit.
    POPND_bit.INT0_PND = 0; // Clear pending bit
}

```

```

/**
 * @file name   Charge.c
 * @description charge function for fast charge and supplementary charge
 * @author     Li Baoke(86-571-86726288 EXT.8103, baoke.li@samsung.com)
 * @version    Preliminary 0.0
 * @history    |-----|
 *             |ver type when      who                what
 *             |---+---+---+---+---+---+---+---+---+
 *             |0.0 NEW 2008-03-06  Li Baoke           Creation
 */
#include "Globle_Define.h"
#include "Charge.h"
#include "Monitor.h"
#include "Operation.h"
/*Fast charge process*/
void Fast_Charge(void)
{
    unsigned char i;
    /*****calculate the average voltage*****/
    if(Bat1VoltsArray[0] == 0) //in the inita state,set the first as Bat1Volts
    {
        for(i=0; i<8;i++)
            Bat1VoltsArray[i] = Bat1Volts;
    }
    for(i = 8; i>0; i--) //array data rotate right one.
        Bat1VoltsArray[i] = Bat1VoltsArray[i-1];
    Bat1VoltsArray[0] = Bat1Volts; //set the first the data as the newest voltage sample value
    Bat1VoltsArray[8] = 0; //the last one set as 0
    for(i = 0; i<8; i++) //get sum of the 8 data.
        Bat1VoltsArray[8] += Bat1VoltsArray[i];
    Bat1VoltsArray[8] = Bat1VoltsArray[8] / 8; //the last one is the average of the 8 sample values.
    /*****0dv and -dv control*****/
    if ( (Bat1Volts >= START_CHECKING_VOLTAGE) || //0 dv and -dv control: when Vbat > 1.3V,
          (Bat1TimeTotalInterval >= DV_STARTTEST_TIME_LMT) ) //start charging time limit
    {
        Bat1VoltChkFlag = 1;
    }
    if (Bat1VoltChkIntv >= VOLT_CHK_INTV) // 0 dv and -dv control:
    {
        if(Bat1AvgArray[0] == 0)
        {
            for(i=0; i<9;i++)
                Bat1AvgArray[i] = Bat1VoltsArray[8];
        }
        for(i = 8; i>0; i--) //array data rotate right one.
            Bat1AvgArray[i] = Bat1AvgArray[i-1];
        Bat1AvgArray[0] = Bat1VoltsArray[8]; //set the first data as the newest sample value
        Bat1AvgArray[8] = 0; //the last one set as 0
        for(i = 0; i<8; i++) //get sum of the 8 data.
            Bat1AvgArray[8] += Bat1AvgArray[i];
        Bat1AvgArray[8] = Bat1AvgArray[8] / 8; //the last one is the average of the 8 sample.
        if(Bat1AvgArray[8] > Bat1AvgMax)
        {
            Bat1AvgMax = Bat1AvgArray[8];
        }else if(Bat1AvgArray[8] <= Bat1AvgMin)
        {
            Bat1AvgMin = Bat1AvgArray[8];
        }
        if(Bat1AvgMax >= (Bat1AvgArray[8] + 4))
        {
            VoltAvgDropCnt ++;
        }
        if(Bat1AvgMax >= (Bat1AvgArray[8] + 3))
        {
            VoltAvgDropCnt1 ++;
        }
    }
    if(PreVolts == 0)

```

```

    {
        PreVolts = Bat1AvgArray[8];
    }
    if( PreVolts > (Bat1AvgArray[8] ) )
    {
        VoltDropCnt ++;
    }
    if( (Bat1TimeFastInterval % 1200) == 0)
    {
        if(PreVolts1 == 0)
        {
            PreVolts1 = Bat1AvgArray[8];
        }
        if( PreVolts1 > (Bat1AvgArray[8] +1) )
        {
            VoltDropCnt1 ++;
        }
        PreVolts1 = Bat1AvgArray[8];
    }
    PreVolts = Bat1AvgArray[8];
    Bat1VoltChkIntv = 0;        // recounter
}
if((VoltAvgDropCnt >= 10) || (VoltDropCnt >= 10) || (VoltAvgDropCnt1 >= 50) ||(VoltDropCnt1 >= 1))
{
    Bat1State = BATTERY_SUP_CHARGING;
    VoltDropCnt = 0;
}
/* dT/dt check */
DT_Dt_Detect();

if(Bat1TimeFastInterval >= MAX_FAST_INTEVEL)
{
    Bat1TimeFastInterval = 0;
    Bat1TimeFastCounter ++;
}
if( (Bat1TimeFastCounter >= MAX_FAST_COUNTER) ||           //fast charging time control
    (Bat1State == BATTERY_SUP_CHARGING) )
{
    Bat1State = BATTERY_SUP_CHARGING;           //exceed fast charge limit,then enter supplementary charge
} else {
    Battery_Fast_Charge();
    if (Bat1State == NO_BATTERY)
        delay(2000);
    Bat1State = BATTERY_FAST_CHARGING;
}
}
/*
**Supplementary charge process
*/
void Sup_Charge(void)
{
    /* dT/dt check */
    DT_Dt_Detect();

    if(Bat1TimeSupInterval >= MAX_SUP_INTEVEL)
    {
        Bat1TimeSupInterval = 0;
        Bat1TimeSupCounter ++;
    }
    if ((Bat1TimeSupCounter >= MAX_SUP_COUNTER)) //Supplementary charging time control
    {
        Bat1State = BATTERY_TRICKLE_CHARGING;
    } else {
        Bat1State = BATTERY_SUP_CHARGING;
        Battery_Sup_Charge();
    }
}
}

```

```

/*
 * @file name   operation.c
 * @description Battery charger operation of each mode
 * @author     Li Baoke(86-571-86726288 EXT.8103, baoke.li@samsung.com)
 * @version    Preliminary 0.0
 * @history    History type - NEW/MODify/ADD/DELeTe
 *
 * |-----|
 * |ver type when      who                what
 * |---+---+-----+-----|
 * |0.0 NEW 2008-03-06  Li Baoke          Creation
 */
#include "Globle_Define.h"
#include "Operation.h"
/*****Charge operation functions*****/
/*****/
/**
 ** Pre charging function
 */
void Battery_Pre_Charge(void)
{
    if (ChargingCurrent <= PRE_CHG_CURRENT_LMT)
    {
        PWMWidth++;
        if (PWMWidth >= PRE_PWM_MAX)
            PWMWidth = PRE_PWM_MAX;
        PWM_Operation(PWMWidth);
    }else {
        PWMWidth--;
        if (PWMWidth <= PRE_PWM_MIN)
            PWMWidth = PRE_PWM_MIN;
        PWM_Operation(PWMWidth);
    }
}
/**
 ** fast charging function
 */
void Battery_Fast_Charge(void)
{
    if (ChargingCurrent <= FAST_CHG_CURRENT_LMT)
    {
        PWMWidth++;
        if (PWMWidth >= FAST_PWM_MAX)
            PWMWidth = FAST_PWM_MAX;
        PWM_Operation(PWMWidth);
    }else {
        PWMWidth--;
        if (PWMWidth <= FAST_PWM_MIN)
            PWMWidth = FAST_PWM_MIN;
        PWM_Operation(PWMWidth);
    }
}
/**
 ** supplementary charging function
 */
void Battery_Sup_Charge(void)
{
    if (ChargingCurrent <= SUP_CHG_CURRENT_LMT)
    {
        PWMWidth++;
        if (PWMWidth >= SUP_PWM_MAX)
            PWMWidth = SUP_PWM_MAX;
        PWM_Operation(PWMWidth);
    }else {
        PWMWidth--;
        if (PWMWidth <= SUP_PWM_MIN)
            PWMWidth = SUP_PWM_MIN;
    }
}

```

```

    PWM_Operation(PWMWidth);
}
}
/*
** trickle charging function
*/
void Battery_TRK_Charge(void)
{
    if (ChargingCurrent <= TRK_CHG_CURRENT_LMT)
    {
        PWMWidth++;
        if (PWMWidth >= TRK_PWM_MAX)
            PWMWidth = TRK_PWM_MAX;
        PWM_Operation(PWMWidth);
    }else {
        PWMWidth--;
        if (PWMWidth <= TRK_PWM_MIN)
            PWMWidth = TRK_PWM_MIN;
        PWM_Operation(PWMWidth);
    }
}
}
/*****
***** PWM operation functions*****
*****/
void PWM_Duty_Set(unsigned char dutywidth) //set PWM dutywidth
{
    PWMDATA = dutywidth <<2; //set PWMDATA.5-2 = dutywidth
}
void PWM_Exten_Set(unsigned char ext) //set PWM extension bit
{
    PWMDATA |= ext; //set PWMDATA.1-0
}
void PWM_Start_Run(void) //PWM start counter
{
    PWMCON |= 0x04;
}
void PWM_Stop_counter(void) //PWM stop counter
{
    PWMCON &= 0xFB; // &11111011B (bit2 = 0);
}
void PWM_Enable_Interrupt(void) //PWM interrpt enable
{
    PWMCON |= 0x02;
}
void PWM_Clock_Select_64(void)
{
    PWMCON &= 0x3F; // &00111111B (bit7.-6 = 00)
}
void PWM_Clock_Select_8(void)
{
    PWMCON &= 0x7F; // &01111111B (bit7 = 0)
    PWMCON |= 0x40; // |01000000B (bit6 = 1)
}
void PWM_Clock_Select_2(void)
{
    PWMCON &= 0xBF; // &10111111B (bit6 = 0)
    PWMCON |= 0x80; // |10000000B (bit7 = 1)
}
void PWM_Clock_Select_1(void)
{
    PWMCON |= 0xC0; // |11000000B (bit6 = 1)
}
void PWM_Operation(unsigned char width)
{
    unsigned char Temp, Temp2;
    //set P0.6 as PWM output:
    P0CONH &= 0xDF; //&11011111B (bit5 = 0)
}

```

```

P0CONH |= 0x10; //|00010000B (bit4 = 1)
Temp = width / 4;
Temp2 = (Temp & 0x3F)<<2;
//PWM_Duty_Set(Temp);
Temp = width % 4;
Temp2 = Temp2 | (Temp & 0x03);
//PWM_Exten_Set(Temp);
PWMDATA = Temp2;
PWMRunFlag = CHARGING_RUN; //PWM state: run
PWM_Start_Run();
}
void PWM_Stop(void)
{
    PWM_Stop_counter();
    //set P0.6 as output :
    P0CONH &= 0xCF; //&11101111B (bit5 = 0)
    P0CONH |= 0x20; //|00100000B (bit4 = 1)
    P0_bit.b6 = 0; //output low to stop charging
    PWMRunFlag = 2; //PWM state: stop run
}
/*****
***** battery state Display *****/
void Show_BAT1_State(unsigned char State_Flag) //battery 1 state show
{
    if( Bat1State == NO_BATTERY) //no battery , Red LED blink
    {
        P2_bit.b2 = 0; //Led_Green_1 turn off,
        if( TOMatchCounter == 30)
        {
            TOMatchCounter = 0;
            P2_bit.b1 = ~P2_bit.b1; //Led_Red_1 blinking slowly
        }
    }
    }else if(Bat1State == BATTERY_TYPE_ERROR) //battery type wrong , Red LED blink
    {
        P2_bit.b2 = 0; //Led_Green_1 turn off,
        if( TOMatchCounter == 4)
        {
            TOMatchCounter = 0;
            P2_bit.b1 = ~P2_bit.b1; //Led_Red_1 blinking quickly
        }
    }
    }else if(Bat1State == BATTERY_PRE_CHARGING) //battery precharg, Green LED blink
    {
        P2_bit.b1 = 0; //LED_Red_1 turn off
        if(TOMatchCounter == 18)
        {
            TOMatchCounter = 0;
            P2_bit.b2 = ~P2_bit.b2; //Led_Green_1 blinking slowly
        }
    }
    }else if(Bat1State == BATTERY_FAST_CHARGING) //battery fast charging , Green LED blink
    {
        P2_bit.b1 = 0; //LED_Red_1 turn off
        if(TOMatchCounter == 2)
        {
            TOMatchCounter = 0;
            P2_bit.b2 = ~P2_bit.b2; //Led_Green_1 blinking quickly
        }
    }
    }else if (Bat1State == BATTERY_SUP_CHARGING) //battery supplementary charging,Green LED blink
    {
        P2_bit.b1 = 0; //LED_Red_1 turn off
        if(TOMatchCounter == 10)
        {
            TOMatchCounter = 0;
            P2_bit.b2 = ~P2_bit.b2; //Led_Green_1 blinking normally
        }
    }
    }else if (Bat1State == BATTERY_TRICKLE_CHARGING) //battery trickle charging

```

```
{
    P2_bit.b1 = 0; //LED_Red_1 turn off
    if(TOMatchCounter == 26)
    {
        TOMatchCounter = 0;
        P2_bit.b2 = ~P2_bit.b2; //Led_Green_1 blinking very slowly
    }
}
}else if (Bat1State == BATTERY_CHARGING_END) //battery charging end. Red LED blink (same with no battery)
{
    P2_bit.b2 = 0; //Led_Green_1 turn off,
    if( TOMatchCounter == 30)
    {
        TOMatchCounter = 0;
        P2_bit.b1 = ~P2_bit.b1; //Led_Red_1 blinking slowly
    }
}
}
```

```

/*
 * @file name   Monitor.c
 * @description measurement functions and system abnormal state protect
 * @author     Li Baoke(86-571-86726288 EXT.8103, baoke.li@samsung.com)
 * @version    Preliminary 0.0
 * @history    History type - NEW/MODify/ADD/DELeTe
 *
 * |-----|
 * |ver type when      who      what
 * |---+---+-----+-----+
 * |0.0 NEW 2008-03-06  Li Baoke      Creation
 */

/*****
***** INCLUDES *****/
/*****/
#include "Globle_Define.h"
#include "monitor.h"
#include "Operation.h"
/*****
***** parameter measurement *****/
/*****/
/* battery 1 voltage convert (amplifier output) */
unsigned int BAT1_V_Monitor(void)
{
    unsigned int ADC_Result = 0;           //store convert result
    __disable_interrupt();                //disable interrupt
    ADCON = 0x34;                          //00110100b
                                           //ADC channel 3(P0.3, A_BAT1)
    ADC_Start_Convert();                  //Start convert
    while(ADCON_bit.EOC == 0);
    ADC_Result = ADDATAH;                  //load ADDATAH
    ADC_Result = ((ADC_Result<<2) & 0x03FC) | (ADDATAL & 0x03); //get convert result
    __enable_interrupt();                 //enable interrupt

    return ADC_Result;
}
/* charging current convert (amplifier output) */
unsigned int Charging_Current_Monitor(void)
{
    unsigned int ADC_Result = 0;           //store convert result
    __disable_interrupt();                //disable interrupt
    ADCON = 0x84;                          //10000100b
                                           //ADC channel 8(P2.6, charging current)

    ADC_Start_Convert();                  //Start convert

    while(ADCON_bit.EOC == 0)
    {
        __no_operation();
    }
    ADC_Result = ADDATAH;                  //load ADDATAH
    ADC_Result = ((ADC_Result<<2) & 0x03FC) | (ADDATAL & 0x03); //get convert result
    __enable_interrupt();                 //enable interrupt

    return ADC_Result;
}
/* battery 2 voltage convert (amplifier output) */
unsigned int BAT2_V_Monitor(void)
{
    unsigned int ADC_Result = 0;           //store convert result
    __disable_interrupt();                //disable interrupt
    ADCON = 0x44;                          //01000100b
                                           //ADC channel 4(P0.4, A_BAT2)
    ADC_Start_Convert();                  //Start convert
    while(ADCON_bit.EOC == 0);

    ADC_Result = ADDATAH;                  //load ADDATAH

```

```

    ADC_Result = ((ADC_Result<<2) & 0x03FC) | (ADDATA1 & 0x03); //get convert result
    __enable_interrupt(); //enable interrupt

    return ADC_Result;
}
/* battery 1 temp. convert (amplifier output) */
unsigned int BAT1_Temp_Monitor(void)
{
    unsigned int ADC_Result = 0; //store convert result
    __disable_interrupt(); //disable interrupt
    ADCON = 0x14; //01000100b
    //ADC channel 1(P0.1, A_Temp_BT1)
    ADC_Start_Convert(); //Start convert
    while(ADCON_bit.EOC == 0);

    ADC_Result = ADDATAH; //load ADDATAH
    ADC_Result = ((ADC_Result<<2) & 0x03FC) | (ADDATA1 & 0x03); //get convert result
    __enable_interrupt(); //enable interrupt

    return ADC_Result;
}
/* battery 2 temp. convert (amplifier output) */
unsigned int BAT2_Temp_Monitor(void)
{
    unsigned int ADC_Result = 0; //store convert result
    __disable_interrupt(); //disable interrupt
    ADCON = 0x74; //01110100b
    //ADC channel 1(P0.1, A_Temp_BT1)
    ADC_Start_Convert(); //Start convert
    while(ADCON_bit.EOC == 0);

    ADC_Result = ADDATAH; //load ADDATAH
    ADC_Result = ((ADC_Result<<2) & 0x03FC) | (ADDATA1 & 0x03); //get convert result
    __enable_interrupt(); //enable interrupt

    return ADC_Result;
}
/*****
***** charge condition detector *****/
void Max_Temp_Detect()
{
    Bat1TempADC = BAT1_Temp_Monitor(); //get temp signal convert result
    Bat1Temp = ( 43676 - (60 * Bat1TempADC) ) / (1024 - Bat1TempADC); //temp calculate forum
    if (Bat1Temp >= 35) //temperature control: if Temp > 45C, stop fast or
    supplementary charging and enter trickle charging
    {
        Bat1State = BATTERY_TRICKLE_CHARGING;
    }
}
void DT_Dt_Detect()
{
    if(Bat1TempChkIntv >= 2400) //dT / dt : temperature control:
    {
        if(Bat1Temp > (Bat1PreTemp + 1 ) )
        {
            Bat1State = BATTERY_TRICKLE_CHARGING;
        }
        Bat1TempChkIntv = 0;
        Bat1PreTemp = Bat1Temp;
    }
}
void Max_ChargeTime_Detect()
{
    if(Bat1TimeTotalInterval >= MAX_TOTOL_INTEVEL)
    {
        Bat1TimeTotalInterval = 0;
    }
}

```

```
Bat1TimeTotalCounter ++;
}
if(Bat1TimeTotalCounter >= MAX_TOTOL_COUNTER)
{
    Bat1State = BATTERY_TRICKLE_CHARGING;    //if exceed charge timing limitation, enter trickle charge
}
}
/*****
***** ADC operation *****/
void ADC_Start_Convert(void)
{
    ADCON |= 0x01;                          // |00000001B (bit0 = 1)
}
```

```

/**
 * @file name Global_Define.h
 * @description global variables and definitions.
 * @author Li Baoke(86-571-86726288 EXT.8103, baoke.li@samsung.com)
 * @version Preliminary 0.0
 * @historyHistory type - NEW/MODify/ADD/DELeTe
 *
 * |-----|
 * |ver type when      who              what
 * |---+---+-----+-----|
 * |0.0 NEW 2008-03-06  Li Baoke        Creation
 * |-----|
 */

#ifndef __GLOBLE_DEFINE_H
#define __GLOBLE_DEFINE_H
/* Header file including union declaration of registers. */
#include "ioS3C9454.h"
/* This header file contains some intrinsic functions. */
#include "intrinsic.h"
/*****
*****  DECLARATION  *****/
*****/

void Sys_init();
void System_Clear();
void delay(unsigned int nLoop_CNT);
/*****
***** Charge Status define *****/
*****/

#define NO_BATTERY                0                //no battery insert or battery inversed
#define BATTERY_TYPE_ERROR        1                //battery type not correct
#define BATTERY_PRE_CHARGING      2                //battery in pre-charging
#define BATTERY_FAST_CHARGING     3                //battery in fast charging
#define BATTERY_SUP_CHARGING      4                //battery charging finished
#define BATTERY_TRICKLE_CHARGING  5                //battery charging finished
#define BATTERY_CHARGING_END      6                //battery charging finished
/*****
***** System parameter define *****/
*****/

/*-----
*
*                ADC convert parameters
*-----*/

#define CURRENT_AMP_GAIN          46                //current monitor amplifier gain.
#define CURRENT_AMP_COMPENSATE    14                //compensate for current ADC convert result.
/*-----
*
*                charging state change condition
*-----
*
*                voltage = ((2.5Vbat+) + Vbat-)*1024/5
* voltage < 50:      no battery or battery was inversed
* 615 < voltage < 790:  fast charging / supplementary charging /trickle charing
* voltage > 790:     battery type wrong or charing finished.
* charing current < 15: no battery or battery was token off
*/

#define BAT_DETECTOR_VOLTS        50                //when battery voltage bigger than this value, means battery on.
#define BAT_PREEND_VOLTS          615              //when battery voltage bigger than this value, stop pre-charging.
#define BAT_MAX_VOLTS              790              //if voltage bigger than this, stop charing
#define CHG_CURRENT_MIN            15                //if current less than this,means no battery or battery was toke off
#define START_CHECKING_VOLTAGE     790              //dv/0dv start checking voltage
#define DV_STARTTEST_TIME_LMT      20000           //dv/0dv start checking time limit
#define VOLTS_OF_INIT_DLY_1        630              //voltage value 1
#define INIT_CHECK_DLY_1            20000           //if voltage < 630, then delay time will be longer
#define VOLTS_OF_INIT_DLY_2        660              //voltage value 2
#define INIT_CHECK_DLY_2            10000           //if voltage < 660, then delay time will be short
#define VOLTS_OF_INIT_DLY_3        700              //voltage value 1
#define INIT_CHECK_DLY_3            0                //if voltage > 700, then no delay.
/*-----
*
*                charging time control constents
*-----*/

#define CHARGING_RUN                1                //charging runing

```

```

#define MAX_TOTOL_INTEVEL          60000 //total charging time max interval
#define MAX_TOTOL_COUNTER          6     //max total charging time counter
#define MAX_FAST_INTEVEL           12000 //Fast charging time max interval
#define MAX_FAST_COUNTER           6     //max Fast charging time counter
#define MAX_SUP_INTEVEL            60000 //Sup. charging time max interval
#define MAX_SUP_COUNTER            2     //max Sup. charging time counter
#define VOLT_CHK_INTV              40    // -dv/0dv checking interval
/*-----
*                               charging PWM width control constents
*-----*/
#define PRE_PWM_MIN                 40    //pre-charge mimimun duty width
#define PRE_PWM_MAX                 60    //pre-charge maximum duty width
#define PRE_CHG_CURRENT_LMT        30    //pre-charge constant current

#define FAST_PWM_MIN                100   //Fast-charge mimimun duty width
#define FAST_PWM_MAX                220   //Fast-charge maximum duty width
#define FAST_CHG_CURRENT_LMT       340   //Fast-charge constant current

#define SUP_PWM_MIN                 60    //Sup.-charge mimimun duty width
#define SUP_PWM_MAX                 100   //Sup.-charge maximum duty width
#define SUP_CHG_CURRENT_LMT        110   //Sup.-charge constant current

#define TRK_PWM_MIN                 24    //Trickle-charge mimimun duty width
#define TRK_PWM_MAX                 60    //Trickle-charge maximum duty width
#define TRK_CHG_CURRENT_LMT        40    //Trickle-charge constant current
/*****
*****Global Variable definition*****
******/
/*----- Battery related variables -----*/
extern unsigned char Bat1State;           //battery 1 state
/* voltage monitor related */
extern unsigned int  Bat1Volts;           //Battery 1 voltage ADC convert result;
extern unsigned int  Bat1VoltsArray[9];  //voltage sample array, the last one [8] is average value.
extern unsigned int  Bat1AvgArray[9];    //voltage average array, last one is average value.
/* temperature related */
extern unsigned int  Bat1TempADC;        //battery 1 temperature ADC result
extern unsigned int  Bat1Temp;           //battery 1 temperature
extern unsigned int  Bat1PreTemp;        //battery 1 pre temp data
extern unsigned int  Bat1TempChkIntv;    //battery temperature checking interval
/* time control related parameters (time = interval * counter) */
extern unsigned int  Bat1TimeTotalInterval; //battery 1 total charing time interval
extern unsigned char Bat1TimeTotalCounter; //battery 1 total charing time counter
extern unsigned int  Bat1TimeFastInterval; //battery 1 fast charing time interval
extern unsigned char Bat1TimeFastCounter; //battery 1 fast charing time counter
extern unsigned int  Bat1TimeSupInterval; //battery 1 Sup.charing time interval
extern unsigned char Bat1TimeSupCounter; //battery 1 Sup. charing time counter
/*Termination condition check related variables*/
extern unsigned char Bat1VoltChkFlag;    //voltage checking flag:1-start check; 0- no check
extern unsigned int  Bat1VoltChkIntv;    // battery 1 voltage checking interval
extern unsigned int  PreVolts;           //voltage check value: pre-tested value
extern unsigned int  PreVolts1;         //voltage check value: pre-tested value 1
extern unsigned int  VoltDropCnt;        //counter of voltage drop (Prevoltage - Vcheck >= 1)
extern unsigned char VoltDropCnt1;      //counter of voltage drop every 1 minute.
extern unsigned int  Bat1AvgMax;         //Max value of the average voltage
extern unsigned int  Bat1AvgMin;         //Min value of the average voltage
extern unsigned int  VoltAvgDropCnt;     //counter of Vave <= Vmax-4
extern unsigned char VoltAvgDropCnt1;   //counter of Vave <= Vmax-3
extern unsigned int  DvStartTestTime;   //-dv check delay time
/*-----
*                               common variables
*-----*/
extern unsigned char PWMWidth;           //Fast charging pwm duty width
extern unsigned char PWMRunFlag;        //PWM run or stop flag:0 == init; 1== strat run; 2== stop run
extern unsigned int  ChargingCurrent;    //Charging current convert result.
extern unsigned char TOMatchCounter;     // TO interrupt timing counter
#endif /* __GLOBLE_DEFINE_H */

```